



# Model 4200 Manual Ratchet Threader Instructions & Die List

## To Insert New Dies:

- 1 Place die head in upright position as shown in Figure A.
- 2 Remove screws (#4) in cover plate (#2), lift off cover plate and remove old dies.
- 3 Insert new dies into position in die head with throat down as shown in Figure B. Be sure that each die number (#6-Figure B) agrees with the die head slot number (#3-Figure A) in which it is placed.
- 4 Replace the cover (#2) engaging lugs in dies. Replace screws (#4) and tighten screws lightly.
- 5 Slide die head on already threaded nipple or pipe (#5) and turn until dies engage in thread (see Figure C). This assures that each die is seated properly against the lug on the cover - this is required for accurate threading.
- 6 Tighten screws (#4) securely.

### 12R Style Dies NPT

837810	1/8"
837815	1/4"
837820	3/8"
837825	1/2"
837830	3/4"
837835	1"
837840	1-1/4"
837845	1-1/2"
837850	2"

### 12R Style Dies NPSM

837945	1/8"
837950	1/4"
837955	3/8"
837960	1/2"
837965	3/4"
837970	1"
837975	1-1/4"
837980	1-1/2"
837985	2"

### 12R Style Head with Dies - NPT

837375	1/8"
837380	1/4"
837385	3/8"
837390	1/2"
837395	3/4"
837400	1"
837405	1-1/4"
837410	1-1/2"
837415	2"

### 12R Style Head with Dies - NPSM

837555	1/8"
837560	1/4"
837565	3/8"
837570	1/2"
837575	3/4"
837580	1"
837585	1-1/4"
837590	1-1/2"
837595	2"

**Figure A**  
Remove Old Dies

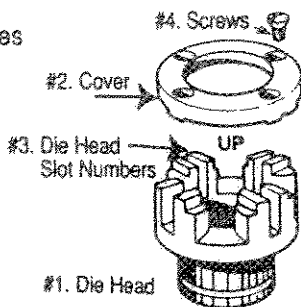

**Figure B**  
New Dies Throat Down  
(Match Numbers)

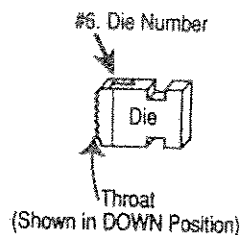

**Figure C**  
Seat Dies - Required!  
(See Step 5 Above)

