

20 Gauge Upholstery Stapler



BSA1116AF

Auto Fire/Long Magazine

Applications

Insulation Installation, Picture Frames, Poly Sheeting,
Roofing Felt Installation, Upholstery

Specifications

Crown	3/8"
Gauge	20
Staple Range	1/4" - 9/16"
Staple Capacity	168
Length	15-1/4" X 1-1/2" X 5-1/2"
Weight	2.6 lbs

Features

Adjustable Speed for Auto Fire,
Bottom Load, Fast, Lightweight, Rear
Exhaust, Rubber Grip For Comfort

Includes

Tool Oil, Manual, Parts Diagram



Double Length Magazine

For best results, use Spotnails® collated fasteners

A-11/T-50 - 3/8" Crown

Stock No.	Length	Competitors Stock No.	M/ Bx	Bx/ Cs	M/Cs	Lbs/ Cs	Cs/ Skid
85504	1/4"	A-11/6	5.0	20	100	22.20	60
85505	5/16"	A-11/8	5.0	20	100	24.60	60
85506	3/8"	A-11/9	5.0	20	100	28.10	60
85508	1/2"	A-11/12	5.0	20	100	34.50	60
85509	9/16"	A-11/14	5.0	20	100	38.60	60
86506	3/8" DP	Div. Point	5.0	20	100	28.40	60

Retail Packaging

85126	3/8"	A-11/9	1.25	32	40	12.30	128
-------	------	--------	------	----	----	-------	-----

304 Stainless Steel

85506SS	3/8"	304 SS	5.0	20	100	31.00	60
---------	------	--------	-----	----	-----	-------	----

Division of Peace Industries, LTD.

Phone: 800-873-2239 ** Fax: 888-369-2588

www.spotnails.com



MODEL BSA1116AF-A SPOTNAILS®

DIVISION OF PEACE INDUSTRIES, LTD.

1100 Hicks Rd
Rolling Meadows, IL 60008
Phone : 847-259-1620

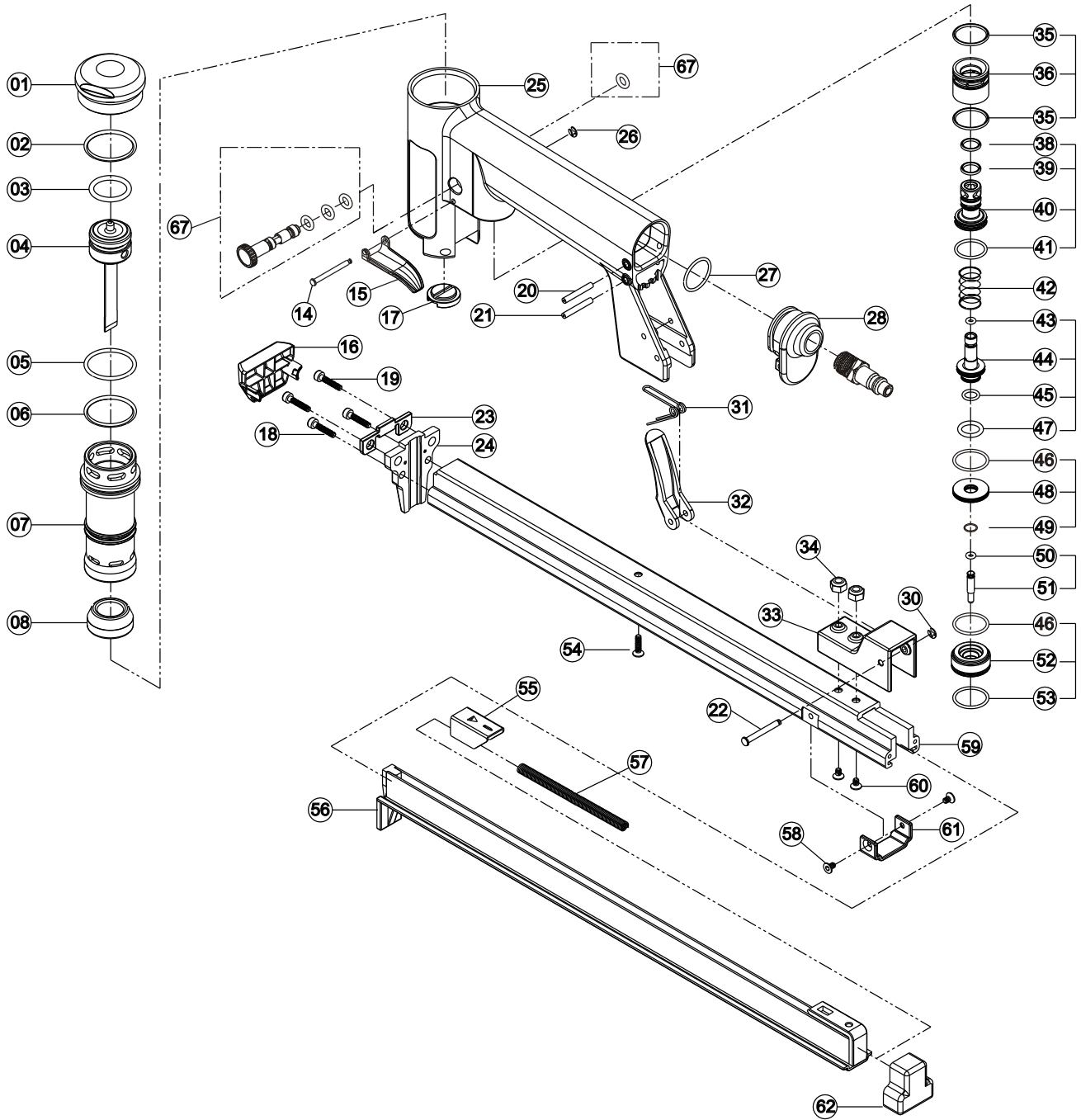

08/25/14



Take notice to the schematic diagram included in this manual

Please contact customer service to place an order for replacement parts:

800-873-2239

Check out our website at www.spotnails.com to browse through the rest of our tool line and fasteners.

Operation, Maintenance and Safety Manual Pneumatic Tools



1100 Hicks Road, Rolling Meadows, IL 60008 USA

Phone: 847-259-1620 * 800-873-2239 Fax: 847-259-9236 * 888-369-2588

www.spotnails.com



PLEASE READ! This manual contains important information about product safety and should be read by all operators of this tool. Contact your Spotnails representative or distributor with any questions concerning the tool and its use.

Spotnails

1100 Hicks Road, Rolling Meadows, IL 60008

1-800-873-2239



TABLE OF CONTENTS

	Page
Safety Instructions	3
Safety Warnings	3
Employer Responsibility	3
Operation	4
Explosion Hazard	5
Air Supply & Connections	5
Loading	6
Tool Service/Maintenance	7
Tool Troubleshooting Guideline	8
Warranty	11

NOTE: Spotnails tools are quality built and designed to provide maximum performance when used with Spotnails fasteners. Spotnails cannot assume responsibility for performance if our tools are used with fasteners or accessories not meeting the same high quality standard as Spotnails fasteners and accessories. Spotnails cannot assume responsibility for performance of tool if tool has been modified or repaired by non-authorized people.

WARRANTY ITEMS

Warranty for cap assembly's, castings and housing castings is one year

Warranty for bumpers, 'o' rings, driver blades and piston rings is not applicable as they are normal wearing parts whose life is dependent on application.

Warranty for all other parts is 90 days.

WARRANTY CONDITIONS

The beginning date in which the warranty is in force is the date of purchase.

The warranty is not transferable.

The warranty is voided by any of the following:

- A. Abuse, misuse or damage to the tool.
- B. Use of parts other than genuine Spotnails parts.
- C. Use of fasteners not designated for use in the tool.
- D. Modifications to the tool that alter the original function or intent of use of the tool by anyone other than Spotnails.

Spotnails retains the right to replace or repair any warranty items it deems necessary.



ALWAYS DISCONNECT TOOL FROM AIR SUPPLY AND REMOVE FASTENERS FROM MAGAZINE PRIOR TO PERFORMING REPAIRS OR CLEARING JAMS

SYMPTOM	CAUSE	FIX
Skipping fasteners	1. Dry piston feed	1. Add oil into air inlet in
	2. Feed piston o-rings	2. Replace o-rings
	3. Check feed pawl to ensure free movement	3. Inspect pawl and wipe clean
	4. Canister bottom has wrong fastener setting	4. Adjust canister bottom for correct length of nails
	5. Broken wire weld nails in canister	5. Remove coil of nails and replace with new coil
Fasteners jamming in canister/tool	1. Wrong fasteners being used	1. Use only recommended fasteners for tool.
	2. Broken wire weld nails in canister	2. Remove coil of nails and replace with new coil

SAFETY INSTRUCTIONS

Before operating this tool, all operators should read this manual to understand and follow all safety warnings before connecting, disconnecting, loading, operating, maintaining, changing accessories on, or working near the tool. Failure to do so can result in serious bodily injury or even death.



Eye Protection

The operator and all personnel in the general area should wear eye protection that conforms to the requirements of ANSI Z87.1. Eye wear must provide protection against flying particles both from the front and side.



Hearing Protection

The operator and all personnel in the general area should wear hearing protection in working area where exposure to loud noise level may cause hearing damage.



Hard Hat Protection

In some environments, it may be necessary to wear head protection that conforms to the requirements of ANSI Z789.1



SAFETY WARNINGS



Failure to follow any of the instructions below could result in severe injury to tool user and bystanders or cause damage to tool and property.

Read and understand all instructions prior to operating tool. Stay alert, focus on your work and use common sense when working with tools. Do not use tool while tired, after having consumed drugs or alcohol or while under the influence of medication. Never point the tool toward yourself or any other person.

Keep bystanders and children away while operating tool. Do not engage in horseplay while using the tool. Respect tool as a working implement. Do not use as a hammer or a wedge. Do not lift, pull or lower tool by the hose.

EMPLOYER RESPONSIBILITY

Employer, tool owner and tool operator are responsible for the safe use of the tool and ensuring that the manufacturers OPERATING AND SAFETY INSTRUCTIONS are available to operators.

Employer is responsible for training the operator in the safe use of the tool and allowing only persons who have read and understand the tool OPERATING AND SAFETY INSTRUCTIONS to operate and/or repair the tool. If tool needs repair, employer is responsible for removing the tool and tagging it for repair.

Employer is responsible in selecting the appropriate tool actuation system for the tool, taking into consideration the work applications for which the tool is used.

Employer is responsible for personal safety when the tool operator and all other personnel in the work area are wearing appropriate eye protection equipment and when required, other appropriate personal protective equipment such as head, hearing and foot protection equipment.

OPERATION



Do not use tool with missing or damaged safety warning labels

Inspect the tool for proper operation prior to use. Check for misalignment or binding of moving parts and any other condition that may affect the tools operation. Do not overreach. Keep proper footing and balance at all times.

Always assume that the tool contains fasteners and never hold or carry the tool with a finger on the trigger or point the tool at yourself or anyone else. Keep hands and body away from fastener discharge area of tool. Do not load tool with fasteners when any one of the operating controls are activated.

Never tamper with the safety device or use the tool if the safety device is not functioning properly.

Do not actuate tool unless tool it is placed firmly against the workpiece. Drive fasteners into proper work surface only and not into other fasteners.

Do not operate tool with any power source other than that specified in tool OPERATING AND SAFETY INSTRUCTIONS. Do not operate tool with any operating pressure other than that specified in tool OPERATING AND SAFETY INSTRUCTIONS.

Always select an actuation system that is appropriate to the fastener application and the training of the operator.

Use extra caution when driving fasteners into existing walls or other blind areas to prevent contact with hidden objects or persons on other side (e.g., wires, pipes, etc.) When working close to an edge of a workpiece or at steep angles, use care to minimize chipping, splintering or splintering or free flight or ricochet of fasteners which may cause injury.

Disconnect the tool when:

- Performing repairs and clearing jams.
- Elevating, lowering or otherwise moving the tool to a new location
- Tool is outside of the operator's supervision or control
- Removing fasteners from the magazine

After driving a fastener, tool may spring back (recoil) causing it to move away from the work surface. To reduce risk of injury always manage recoil by:

- Always maintain control of the tool.
- Allow recoil to move tool away from work surface.
- Do not resist recoil such that tool will be forced back into the work surface. In "contact actuation" mode, if workpiece contact is allowed to re-contact work surface before the trigger is released, an unintended discharge of a fastener will occur.
- Always keep face and body parts away from tool.

ALWAYS DISCONNECT TOOL FROM AIR SUPPLY AND REMOVE FASTENERS FROM MAGAZINE PRIOR TO PERFORMING REPAIRS OR CLEARING JAMS



SYMPTOM

CAUSE

FIX

SYMPTOM	CAUSE	FIX
Skipping fasteners	1. Feed piston in need of lubricant	1. Lubricate feed piston
	2. O-ring of feed piston worn out	2. Replace o-ring
	3. Socket head cap stuck	3. Clean the obstacle that block the cap
	4. Bumper worn out	4. Replace bumper if worn
	5. Nails incorrectly set in magazine	5. Adjust the nail holder and reset the nails properly
	6. Driver blade blocked or bent	6. Clean the obstacle that block the driver blade or replace the driver blade
	7. Air obstructed or air pressure insufficient	7. Clean the obstacle and adjust air under proper pressure
	8. Piston o-ring worn out	8. Replace o-ring
	9. Lack of lubricant	9. Lubricate properly
	10. Feed spring worn out	10. Replace feed spring
	11. Bolts on magazine loose	11. Tighten the bolts
	12. Magazine broken or dirty	12. Replace magazine if worn, clean if necessary
	13. Fasteners too short	13. Use only recommended fasteners
Fasteners will not drive completely into work piece	1. Insufficient air pressure	1. Increase air pressure DO NOT EXCEED 120 PSI
	2. Check depth adjustment setting where applicable	

PLEASE CONTACT CUSTOMER SERVICE FOR TECHNICAL SUPPORT IF YOU HAVE ANY OTHER PROBLEMS: 800-873-2239

TROUBLESHOOTING GUIDELINE



ALWAYS DISCONNECT TOOL FROM AIR SUPPLY AND REMOVE FASTENERS FROM MAGAZINE PRIOR TO PERFORMING REPAIRS OR CLEARING JAMS

SYMPTOM	CAUSE	FIX
Trigger valve housing/stem leaks air	1. O-ring/seals cut or worn	1. Replace O-ring/seals
	2. Valve packing worn out	2. Replace trigger valve assembly
Cap or exhaust cover leaks air	1. Cap seal worn out	1. Replace cap seal
	2. Bolts on cap loose	2. Tighten the bolts
	3. Exhaust valve worn out	3. Replace exhaust valve
Nose leaks air	1. Bolts on nose loose	1. Tighten the bolts
	2. Bumper worn out	2. Replace the bumper
	3. Gasket/o-ring cut or worn	3. Replace gasket/o-ring
Lack of power or no function	1. Air pressure insufficient	1. Adjust air pressure properly between 70-120 PSI
	2. Lack of lubricant	2. Lubricate piston o-ring, cylinder or exhaust valve
	3. Cylinder spring broken	3. Replace cylinder spring
	4. Worn head valve o-rings	4. Replace o-rings
	5. Head valve stuck	5. Disassemble and lubricate
	6. Blocked exhaust	6. Check bumper, head
	7. Trigger assembly worn	7. Replace trigger assembly
	8. Driver not functioning properly	8. Disassemble driver to clean
Nails jammed	1. In wrong specification or poor quality of the nails	1. Apply correct specification and qualified nails
	2. Driver blade worn out	2. Replace driver blade
	3. Bolts loose	3. Tighten the bolts
	4. Driver guide worn out	4. Replace driver guide

EXPLOSION HAZARD

Do not operate tool in explosive atmospheres, such as in the presence of flammable liquids, gases or combustible dust. Some tools will create sparks that can be an ignition source for a fire or explosion.

AIR SUPPLY & CONNECTIONS

Do not use air supply pressures that exceed 120 PSI (8.28 bar or 8.4 kg/mm²)



Use only clean, regulated compressed air as a power source for this tool. Do not use bottle gases, combustible gases or oxygen as a power source for the tool as the tool may explode.

Recommended operating pressure is 80 to 110 p.s.i. (8.28 bar or 8.4 kg/mm²) Do not exceed the recommended maximum operating air pressure as tool wear will be greatly increased.

The air supply must be capable of maintaining the operating air pressure of the tool. Pressure drops in the air supply can reduce the tool's driving power.

If a regulator fails, the pressure delivered to a tool must not exceed 1.5 times the maximum air pressure or 200 psig (13.8 bar) whichever is greater.

Use a pressure regulator to allow visual inspection of the air pressure being delivered to the tool.

Air Hoses

Use air hoses that have rated pressures of up to 150% of the maximum pressure that can be generated by the power source. The supply hose should contain a fitting that will provide quick disconnecting from the male plug on the tool.

Fittings

Install a male pneumatic fitting onto the rear cap of the tool, ensuring that the fitting allows the tool to exhaust any air in the tool when the air hose is disconnected.

Do not use fittings that will not allow the tool to exhaust when the air supply is disconnected.

Lubrication

Use air line lubricators. If lubricators are not available, or if hose lengths exceed 10 feet, add 2 drops of non-detergent 20 weight oil daily into the air inlet of the tool.

Add two drops of non-detergent, 20 weight oil into the male fitting.

Cold Weather Storage

Remove all fasteners from the tool.

Never store the tool in cold weather environments for any duration of time as any frost or ice formation in the tool will cause tool failures.

For prolonged storage, add two drops of oil to the air inlet of the tool prior to discontinuing use. Also clean the exterior of the tool with a mild solvent.

LOADING

Always handle tool with care.

Visually inspect the tool for worn or damaged parts prior to use.

1. Disconnect from air supply
2. Install a male, pneumatic fitting into the rear cap of the tool ensuring that the fitting allows the tool to exhaust any air in the tool when the air hose is disconnected.
3. Add two drops of non-detergent, 20-weight oil into the male fitting.
4. Connecting the Air Hose
 - a. Use a quick connect fitting to the tool and check the air pressure reading on the regulator to ensure it does not exceed 120 p.s.i. Check the tool for any air leaks.
 - b. Place the tool, empty of fasteners, in operating position on a scrap work piece. Fully depress the safety and pull the trigger to verify that the tool cycles.
5. Using the following cycle guidelines, cycle the tool several times to check for proper tool operation.



BEFORE USING VERIFY THE TRIGGER SETTING TO ENSURE IT IS SET FOR DESIRED TRIGGER ACTUATION

Red Trigger – Single-sequential actuation – Restrictive Installed

The tool will not cycle a second time unless both the trigger and safety yoke are fully released and then depressed again.

Black – Contact Actuation – Bump Fire Included

The tool will not cycle a second time unless the trigger and/or safety yoke are fully released and then depressed again.

Blue – Selective Actuation - Instant Conversion Bump/Restrictive

This trigger allows for operator to select either single-sequential actuation or contact actuation. See above for explanation before using.

6. Open the magazine or slide the pusher to the locked position and load the fasteners approved for the use in the tool.
7. Cycle the tool on a scrap piece to evaluate the depth of the penetration by the fastener into the work piece.
8. Adjustable Depth Control
To adjust the depth of penetration, disconnect the air hose, adjust the depth control knob or screw, connect the air hose and cycle the tool on a scrap work piece to evaluate the adjustment.
Repeat as needed to set the correct depth, using the minimum amount of air pressure to drive the fastener.

TOOL SERVICE/MAINTENANCE



Clean and inspect your tool every time you use it

Tool service shall be repaired or equipped only with parts or accessories that are supplied or recommended by Authorized Spotnails repair personnel. Service or repairs by unqualified personnel may result in a risk of injury.

Please refer to the schematic drawing before starting any repairs.

Tool should be inspected periodically and replace any worn or broken parts to keep the tool operating safely and efficiently.

Tighten all screws. Loose screws can result in unsafe operation of tool.

With tool disconnected from the air supply, regularly inspect the safety, the trigger and the spring for free unhindered movement. Never use a tool that requires servicing.

Whenever repairs or replacement of parts inside the body occur, check the piston 'o' ring for adequate grease lubrication.

Periodically clean the magazine and nose of the tool with a mild, non-flammable solvent.

Disconnect tool from power source when not in use, lowering or moving tool to a new location, tool is outside of the operator's supervision or control and removing fasteners from the magazine.

Written approval of the tool manufacturer must be obtained prior to making any modifications to the tool.

