

ELECTRIC TAPPING MACHINE – DMS SERIES

OPERATING MANUAL

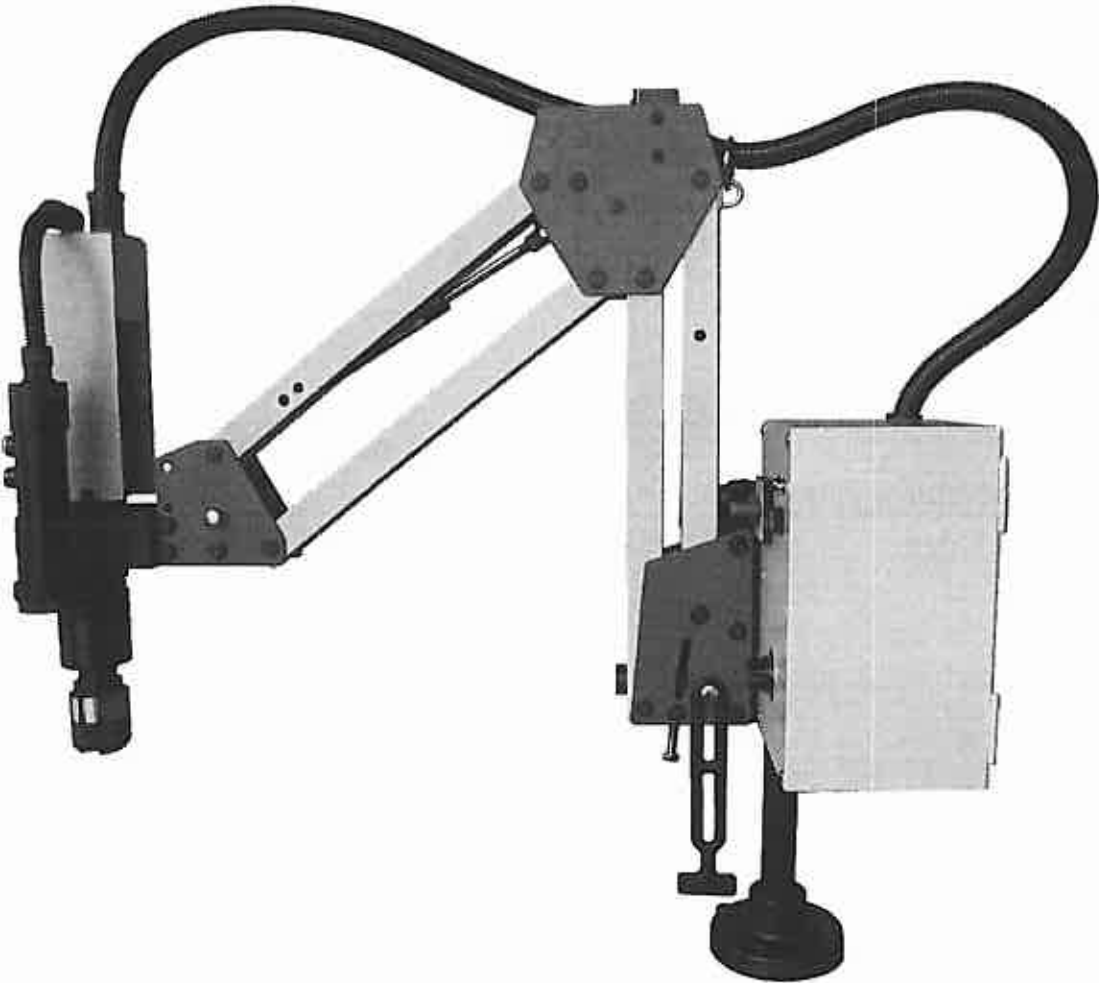

## INDEX

1. DESCRIPTION .....	3
2. UNPACKING .....	3
3. SPECIFICATIONS .....	4
4. SAFETY RULES .....	4
5. BE PREPARED FOR JOB .....	4
6. ASSEMBLY .....	5
7. PREPARATION BEFORE OPERATION .....	6
8. OPERATION .....	7
9. MAINTENANCE .....	8
10. NOTICE FOR USING TOOLS .....	8
11. TROUBLESHOOTING .....	9

## 1. DESCRIPTION

- Electric tapping machine is suitable for different size taps (from M3 to M32).
- The machine is equipped with brushless DC motor and driver for controlling the spindle to tap.
- The arm is equipped with lubricated for life bearings at all swivel points, provides weightless operation through the use of gas counter balance springs and permits the operator to bring the tap to the hole with ease.

## 2. UNPACKING

Please check for completeness. Refer to Figure 2-1.

ITEM DESCRIPTION	MODEL
	DMS-16
A. Stretch arm with electric tapping spindle, driver, motor and wires	•
B. Slanted arm	•
C. Slanted arm rod	•
D. Table mounting column	•

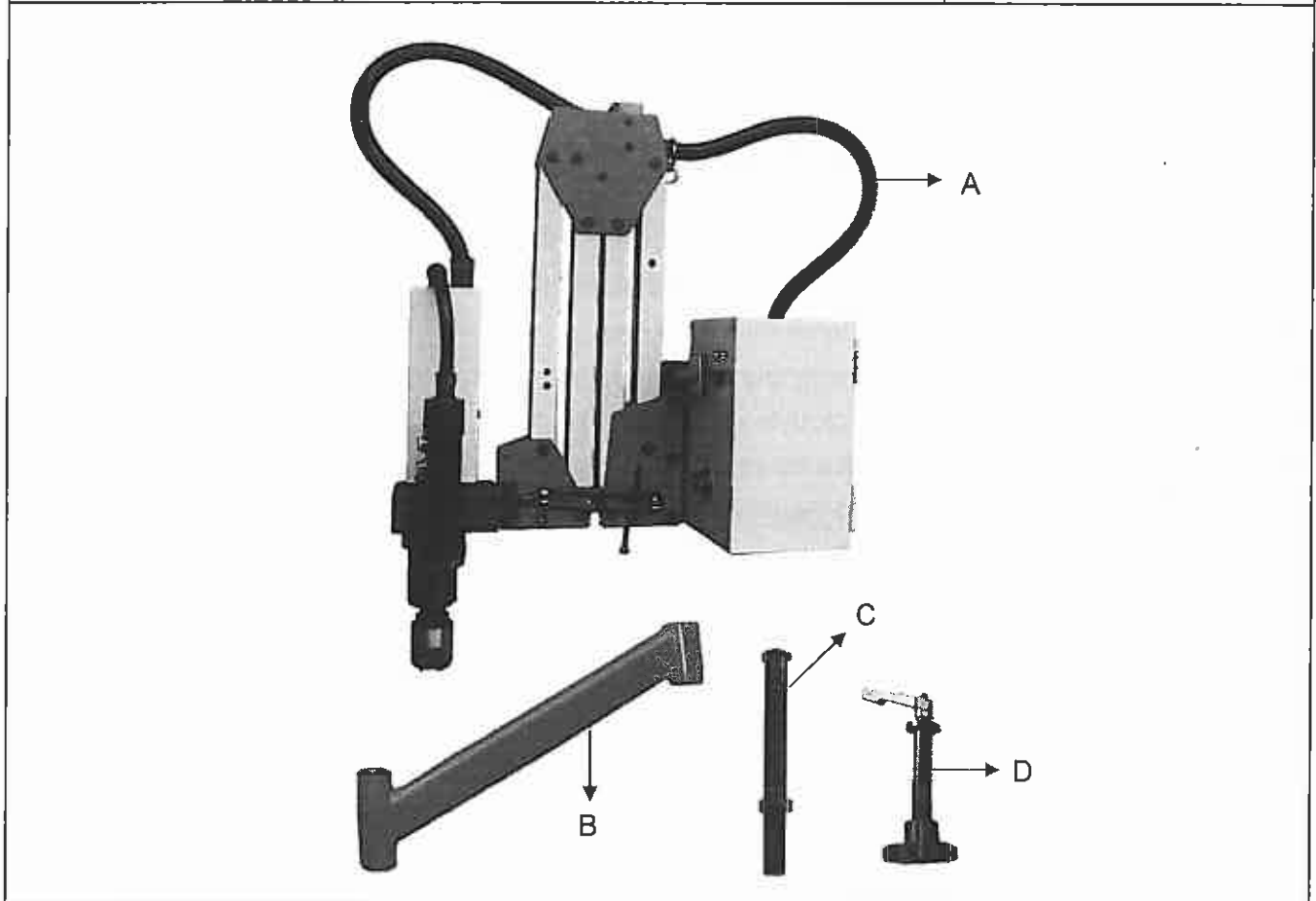

Figure 2-1

### 3. SPECIFICATIONS

Model	DMS-16	
For Tap	M3 ~ M16	
Speed	0~400 / 0~130 rpm	
Tap holder size	TCS2B / TCS1B	
Electric Motor	0.4 kw	
Voltage	110 V Single-Phase	
Work range	Rmax 1400mm	Rmin 200mm

### 4. SAFETY RULES

- Some dust created by power sanding, grinding, drilling and other construction activities contains chemicals known to cause cancer, birth defects or other reproductive harm.
- Always follow this operation manual – even if you are familiar with use this tools. Remember the being careless can result in severe personal injury.
- Be alert and think clearly. Never operate power tools when tired, intoxicated or when taking medications that cause drowsiness.

### 5. BE PREPARED FOR JOB

- Wear proper apparel. Do not wear loose clothing, gloves, neckties, rings, bracelets or other jewelry which may get caught in moving parts of machine.
- Wear protective hair covering to contain long hair.
- Wear safety glasses (not everyday glasses) and shoes with non-slip soles.
- Wear dust mask and dustless clothes if operation is dusty.
- Wear ear protection if the work area may include exposure to excessive noise levels.
- Keep work area ventilation and clean. It should be properly lighted. Cluttered work areas invite accidents.
- Do not use the tools in dangerous environments or wet locations. Do not expose it to rain.

## 6. ASSEMBLY

### STEP 1 : MOUNT TABLE MOUNTING COLUMN

Please assembly the table mounting column to a solid horizontal surface using 10mm bolts (see Figure 6-1).

《Reminder : the machine do not provide bolts.》

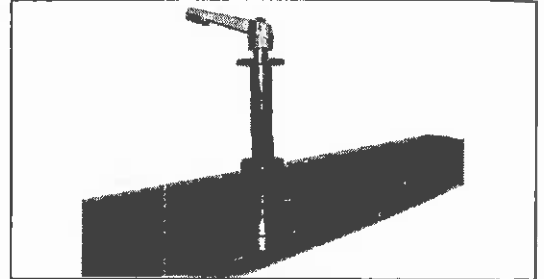

Figure 6-1

### STEP 2 : ATTACH PARALLEL ARM AND SLANTED ARM

See Figure 6-2

- (1) Remove locking handle and washer from table mounting column.
- (2) Slider slanted arm over table mounting column.
- (3) Replace locking handle and washer to secure in position.

See Figure 6-3

- (4) Insert stretch arm rod into slanted arm.
- (5) Remove washer from stretch arm rod.

See Figure 6-4

- (6) Slider Stretch arm (with tapping spindle, driver, motor and wires) into the rod.
- (7) Replace washer to secure in position.

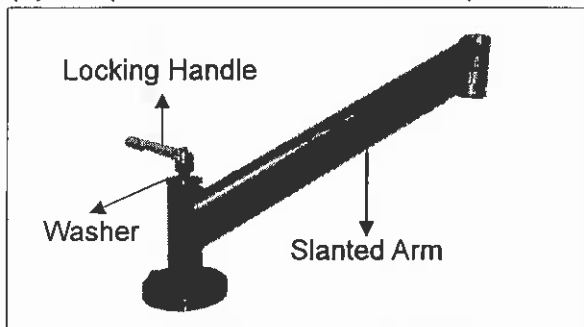

Figure 6-2

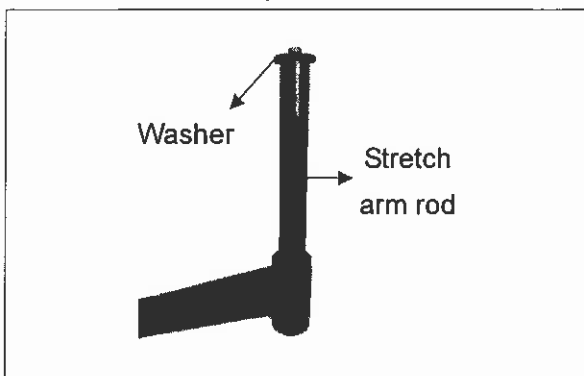

Figure 6-3

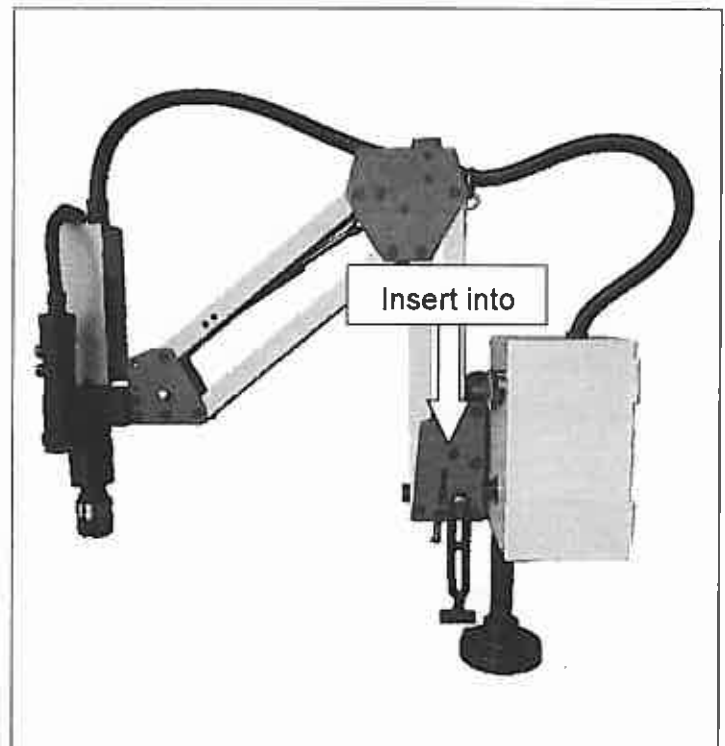

Figure 6-4

## 7. PREPARATION BEFORE OPERATION

### A. ATTACH THE TAP AND TAP HOLDER

- (1) Slide tap into tap holder until tap locks in place. Tap can be removed by simultaneously depressing flange and pulling out tap (see Figure 7-1).
- (2) Insert tap holder with tap into spindle. Pull up tap holder sleeve, insert tap holder with tabs aligned to slots in tap holder sleeve, and then release sleeve (see Figure 7-2).

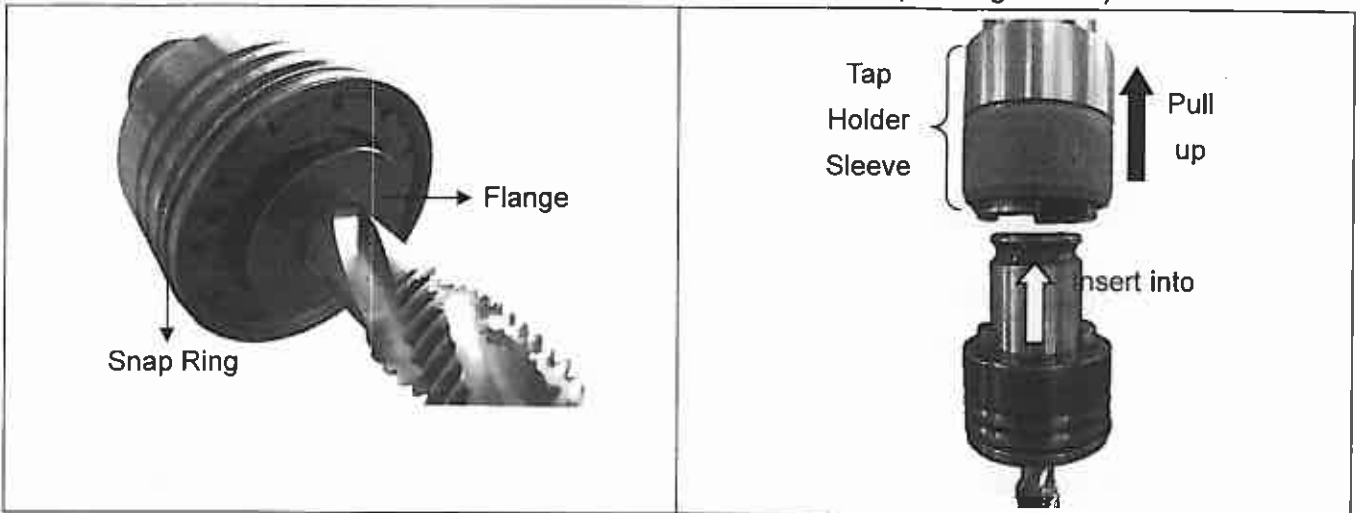

Figure 7-1

Figure 7-2

### B. ADJUST SPEED OF SPINDLE

ⓘ Caution: Never change speed while spindle is in operation. ⓘ

- (1) These models have two speeds. It can be changed by grasping sleeve, pulling downward so that pin is out of the notch in the body, rotating sleeve to the other notch and then releasing the sleeve so that pin seats in the notch.
- (2) Rotate sleeve to seat the pin in the notch. Turn the sleeve clockwise to increase the speed and counter clockwise to reduce the speed.



Figure 7-3

### C. ADJUST AIR SPRING

ⓘ Caution: Never adjust air spring while machine is in operation. ⓘ

※ The stretch arm will be set well before out of factory. ※

- (1) Rotate screw clockwise to make air spring tight, counterclockwise to loosening air spring (see Figure 7-4).

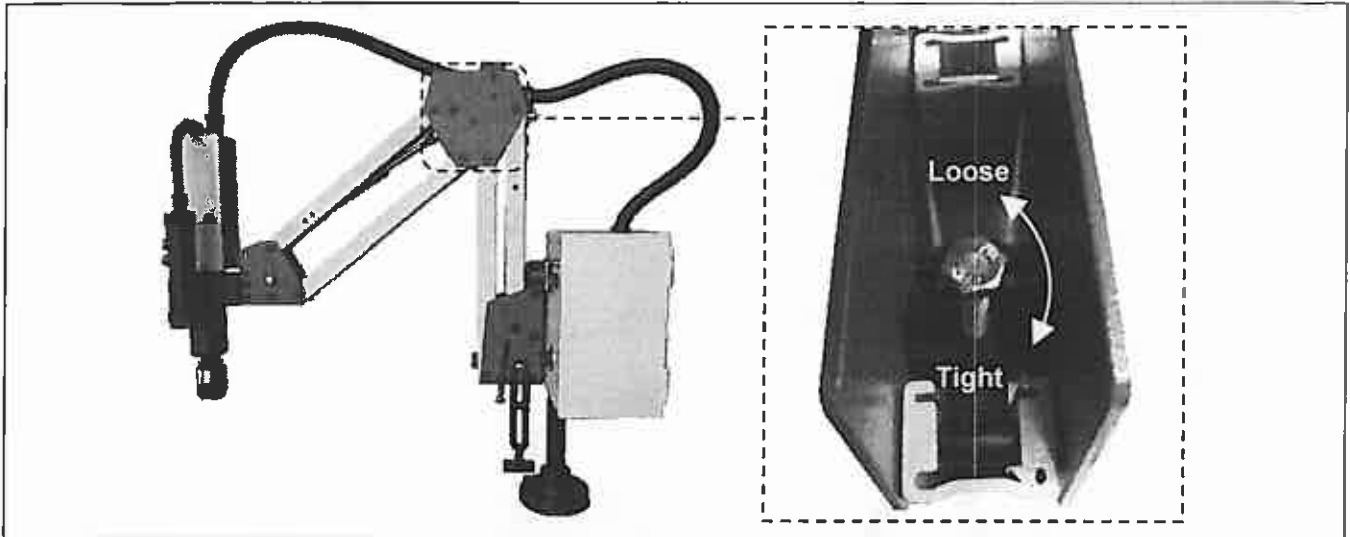

Figure 7-4

## 8. OPERATION

- A. Turn the power on (see Figure 8-1).
- B. Take the spindle with tap to the hole to be tapped and place the tip of the tap on the hole.
- C. Press the clockwise button. The tap will self-center and begin tapping. Let the tap arm guide the tap into the hole (see Figure 8-2).
- D. After tapping to the required depth, press the anti-clockwise button. The tap will reverse out from the hole (see Figure 8-2).

①The motor speed can be adjusted by rotating motor speed adjustment (see Figure 8-1). ①

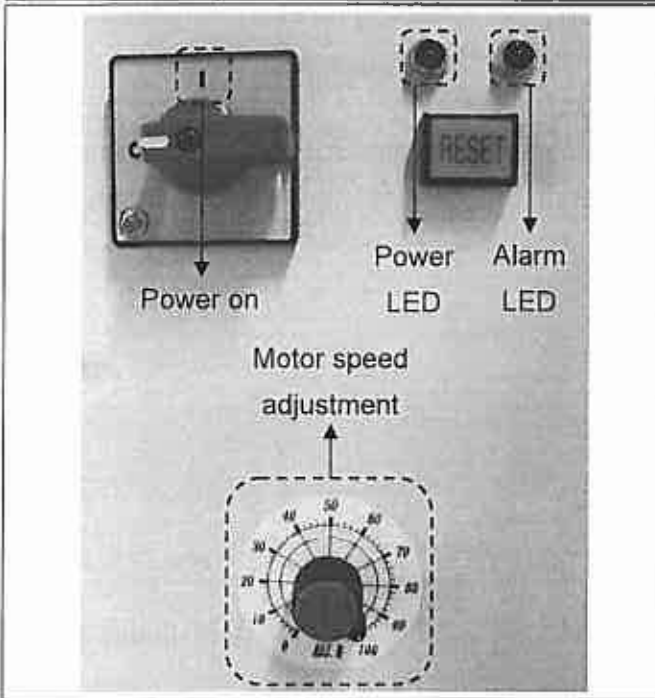

Figure 8-1

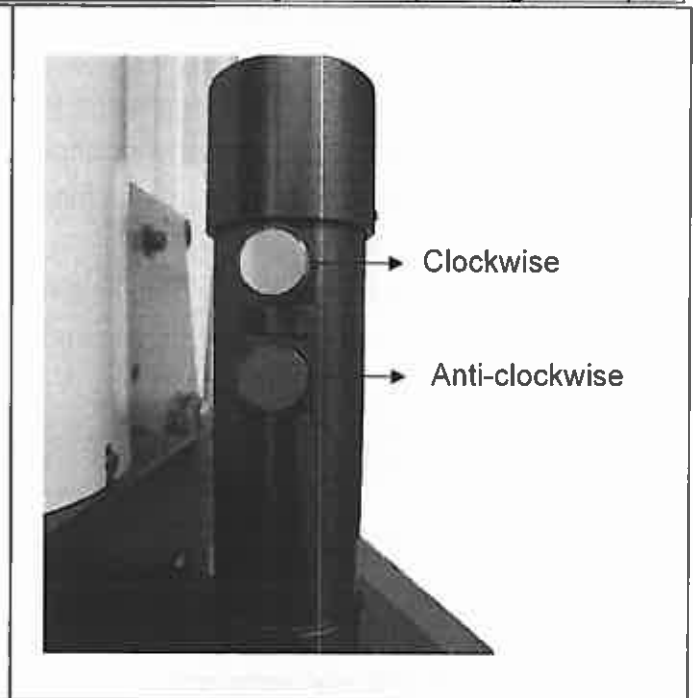

Figure 8-2

**Caution:**

If the tap holder “clicks” or “ratchets”, the tap holder clutch torsion needs to be adjusted.

- (1) Remove the snap ring from the groove of the tap holder (see Figure 7-1).
- (2) Use the tools to adjust the torsion as Figure 8-3.
- (3) Rotate notched nut clockwise to increase torsion, counterclockwise to decrease torsion (see Figure 8-4).
- (4) Replace spring clip into groove of the tap holder.



Figure 8-3

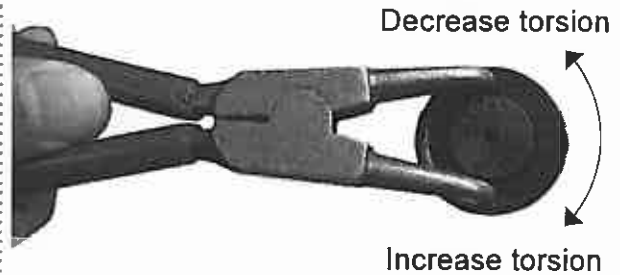

Figure 8-4

## 9. MAINTENANCE

- A. Always unplug tool prior to inspection.
- B. Do not adjust, remove or maintain tool in operation.
- C. Consult manual for specific maintaining and adjusting procedures.
- D. Keep tool lubricated and clean for safest operation.
- E. Remove adjusting tools. Form habit of checking to see that adjusting tools are removed before switching machine on.
- F. Check for damaged parts. It may affect a tool's operation.
- G. Damaged parts should be properly repaired or replaced. Do not perform makeshift repairs.
- H. Never brush away chips while the machine is in operation. All clean up should be done when the machine is stopped.
- I. Never modify machine without consulting manufacturer.
- J. Use sharp cutters and keep the tool clean for safest operation.

## 10. NOTICE FOR USING TOOLS

- A. Keep visitors at a safe distance from work area.
- B. Keep children out of workplace.
- C. All workpieces must be clamped to work table when using tapping machine. It is unsafe to use your hands to hold any workpiece.
- D. Avoid accidental start-up. Make sure that tool switch is in OFF position before connection to air supply.



- E. Do not force tool. It will work most efficiently at the rate for which it was designed.
- F. Keep hands away from moving parts. Protect hands from possible injury.
- G. Never leave a tool running unattended. Turn the power off and do not leave tool until comes o a complete stop.
- H. Do not use tool for a long time. Please take a rest for 5-10 minutes after using one hour.

## 11. TROUBLESHOOTING

SYMPTOM	POSSIBLE CAUSE(S)	CORRECTIVE ACTION
Clutch slips and tap will not turn	Tap holder clutch torsion needs to be adjusted.	Adjust tap holder torsion (see Figure 8-3 and 8-4)
	Not tap lubrication	Apply lubrication to tap
	Dull tap	Replace tap
	Hole and tap misaligned	Reposition tap arm
	Hole diameter too small	Enlarge hole
	Wrong tap for workpiece materials	Replace tap
Spindle does not turn or stops	Workpiece material with hardness	According to the hardness, upgrade bigger capacity spindle
Stretch arm drops or is difficult to move	loose air spring	Adjust air spring (see Figure 7-4)
	Worn air spring	Replace air spring (Air spring is a consumable product.)
Spindle body is hot	Use spindle for a long time	Let your spindle rest for 15 minutes  <b>Caution:</b> Keep using a hot spindle will cause the spindle gear lubricant evaporating and break easily.

**【LED indicator】**

LED	Function	Description
RED	ALARM	Light up when in abnormal activity(or blinking)
GREEN	POWER	Light up when AC power connecting

**【Trouble shooting for LED indicator】**

Condition	LED indicator	Possible Explanation	Solution
Motor can't be started or motor stop after running	POWER LED off	Power disconnecting	Make sure the power cord is connected securely and Power on again.
		Power connected , LED still off	Call distributor or change a new driver.
	ALARM LED on	E-BRAKE on	Check E-BRAKE pin to COM-X, if it's short circuit, release it.
	ALARM LED blink 1,8,9 times	OCP (Over load)	Upgrade to higher power model motor driver or Contact distributor
Motor can't be started or motor stop after running	ALARM LED blink 3,10 times	Out of phase or Missing phase	Check and see if UVW wiring is mistake or connected properly. Correct it or screwed tightly.
	ALARM LED Blink 4,5,6 times	Over Voltage Protection	Regeneration voltage is too high
	ALARM LED Blink 7 times	Low Voltage Protection	Check the line voltage.
	ALARM LED Blink 16 times	Over Heat Protection	Check and see whether ventilation is permitted in the installation environment. Use a fan to ventilate if necessary.



