

# PALMGREN

## 20" FLOOR MODEL DRILL PRESS WITH SINGLE PHASE(9680209) WITH THREE PHASE (9680210)

*Read carefully and follow all safety rules and operating instructions before first use of this product.*

## DESCRIPTION

Palmgren Drill Presses feature a heavy cast iron base, column collar, work table and head. Work table height is adjustable using rack and pinion. Table can be tilted 45° both right and left, and rotates 360° on a vertical axis. Work table surface is precision ground and features T-slots for secure, accurate mounting of workpiece and also a coolant trough. Digital readout displays spindle RPM. Other features of the Palmgren drill press are an enclosed ball bearing quill assembly, quick belt change and tension mechanism, positive quick-adjust feed depth stop and a 1½ HP, 16 speeds motor. Chuck and chuck arbor are included.

Palmgren drill presses are ideal for use in home shops, maintenance shops and light industrial applications. Spindle speeds are adjustable for drilling steel, cast iron, aluminum, wood and plastic.

## UNPACKING

Refer to Figure 1.

**WARNING:** Be careful not to touch overhead power lines, piping, lighting, etc., if lifting equipment is used. Drill press weighs up to 274 lbs, proper tools, equipment and qualified personnel should be employed in all phases of unpacking and installation.

Crates should be handled with care to avoid damage from dropping, bumping, etc. Store and unpack crates with correct side up. After uncrating drill press, inspect carefully for any damage that may have occurred during transit. Check for loose, missing or damaged parts. If any damage or loss has occurred, claim must be filed with carrier immediately. Check for completeness. Immediately report missing parts to dealer.

Drill press is shipped unassembled. Locate and identify the following assemblies and loose parts:

- |                     |                                |
|---------------------|--------------------------------|
| A Head Assembly     | F Feed Handle Bar              |
| B Table Bracket     | G Table Crank Handle           |
| C Base              | H Table Bracket Locking Handle |
| D Column Assembly   | I Chuck & Spindle Arbor        |
| E Quill Feed Handle |                                |

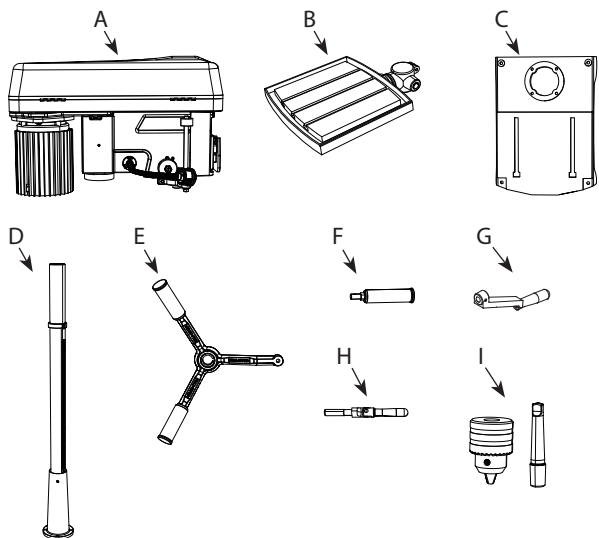

**Figure 1 - Unpacking**

Not Shown: Worm Gear, four M10\*1.5-40 Hex Bolts, Wedge, 3 and 5 mm Hex Wrenches, Chuck Key, Belt Tension Handle, Hardware Bag For Quill Feed Handle.

**IMPORTANT:** The tool has been coated with a protective coating. In order to ensure proper fit and operation the coating must be removed. Remove coating with mild solvents such as mineral spirits and a soft cloth. Nonflammable solvents are recommended. After cleaning, cover all exposed surfaces with a light coating of oil. Paste wax is recommended for table top.

**CAUTION:** Never use highly volatile solvents. Avoid getting cleaning solution on paint as it may tend to deteriorate these finishes. Use soap and water on painted components.

## SPECIFICATIONS

Chuck size .....	.19 mm, JT4
Spindle taper .....	MT3
Spindle travel .....	.6"
Speeds .....	16
RPM .....	120 - 3605
Table size .....	.19-1/4 x 18-3/7"
Base size .....	24-1/7 x 17-5/7"
Overall height .....	.69-7/8"
Weight .....	274 lbs
Motor:	
Single phase (9680209) .....	1-1/2 HP, 120/240 V, 14.2 A/7.1A, 60 Hz (Tool Prewired 120 V)
Three phase (9680210) .....	1 HP, 240 V, 4.5 A, 60 Hz

## SAFETY RULES

**PROPOSITION 65 WARNING:** Some dust created by power sanding, sawing, grinding, drilling and other construction activities contains chemicals known to the state of California to cause cancer, birth defects or other reproductive harm.

Some examples of these chemicals are:

- Lead from lead-based paints.
- Crystalline silica from bricks and cement and other masonry products.
- Arsenic and chromium from chemically-treated lumber.

Your risk from these exposures vary, depending on how often you do this type of work. To reduce your exposure to these chemicals: work in a well ventilated area and work with approved safety equipment. Always wear **OSHA/NIOSH** approved, properly fitting face mask or respirator when using such tools.

Before any work is done, carefully read the cautions listed. Working safely prevents accidents.

## BE PREPARED FOR JOB

- Wear proper apparel. Do not wear loose clothing, gloves, neckties, rings, bracelets or other jewelry which may get caught in moving parts of machine.
- Wear protective hair covering to contain long hair.
- Wear safety shoes with non-slip soles.
- Wear safety glasses which comply with United States ANSI Z87.1. Everyday glasses have only impact resistant lenses. They are NOT safety glasses.
- Wear face mask or dust mask if cutting operation is dusty.
- Be alert and think clearly. Never operate power tools when tired, intoxicated or when taking medications that cause drowsiness.

**WORK AREA SHOULD BE READY FOR JOB**

- Keep work area clean. Cluttered work areas and work benches invite accidents.
- Do not use power tools in dangerous environments. Do not use power tools in damp or wet locations. Do not expose power tools to rain.
- Work area should be properly lighted.
- Proper electrical outlet should be available for tool. Three-prong plug should be plugged directly into properly grounded, three-prong receptacle.
- Extension cords should have a grounding prong, and the three wires of the extension cord should be of the correct gauge.
- Keep visitors at a safe distance from work area.
- Keep children out of workplace. Make workshop childproof. Use padlocks, master switches or remove switch keys to prevent any unintentional use of power tools.

**TOOL SHOULD BE MAINTAINED**

- Always unplug tool prior to inspection.
- Read operating instructions manual for specific maintaining and adjusting procedures.
- Keep tool lubricated.
- Use sharp cutters and keep the tool clean for safest operation.
- Remove adjusting tools. Form the habit of checking that adjusting tools are removed before turning on the machine.
- Keep all parts in working order. Check to determine that the guard or other parts will operate properly and perform their intended function.
- Check for damaged parts. Check for alignment of moving parts, binding, breakage, mounting and any other condition that may affect a tool's operation.
- Damaged parts should be properly repaired or replaced. Do not perform makeshift repairs. (Use the parts list provided to order replacement parts.)

**KNOW HOW TO USE TOOL**

- Use the right tool for the job. Do not force tool or attachment to do a job for which it was not designed.
- Disconnect tool when changing accessories such as bits, cutters and the like.
- Avoid accidental start-up. Make sure switch is in OFF position before plugging in.
- Do not force tool. It will work most efficiently at the rate for which it was designed.
- Handle workpiece correctly. Secure work with clamps or vise. Leave hands free to operate machine. Protect hands from possible injury.
- Never leave a tool running unattended. Turn the power off and do not leave tool until it comes to a complete stop.
- Do not overreach. Keep proper footing and balance.
- Never stand on tool. Serious injury could occur if tool is tipped or if cutter is unintentionally contacted.
- Keep hands away from moving parts and cutting surfaces.
- Know your tool. Learn its operation, application and specific limitations.

- Feed work into a bit or cutter against the direction of rotation of bit or cutter.
- Turn the machine off if it jams. A cutter jams when it digs too deeply into the workpiece. (The motor force keeps it stuck in workpiece.)
- Use recommended accessories.
- Clamp workpiece or brace against column to prevent rotation.
- Use recommended speed for drill accessory and workpiece material.

**WARNING:** Think Safety! Safety is a combination of operator common sense and alertness at all times when drill press is being used.

**ASSEMBLY****INSTALL COLUMN TO BASE**

Refer to Figure 7.

- Position the base (Ref. No. 4) on a flat work surface.
- Mount column assembly (Ref. No. 8) to base using four hex bolts (Ref. No. 11).

**INSTALL TABLE TO COLUMN ASSEMBLY**

Refer to Figure 7.

- Insert the worm gear (Ref. No. 34) into the table crank handle hole from inside the table bracket (Ref. No. 26). Make sure the worm gear (Ref. No. 34) meshes with the inside raising/lowering gear.
- Install the table bracket locking handle (Ref. No. 33) into the hole at the rear of the table bracket (Ref. No. 26).  
**NOTE:** Install the handle from left to right, so it enters the non-threaded side of the table bracket first.
- Place the rack (Ref. No. 14) inside the table bracket (Ref. No. 26), making sure the worm gear (Ref. No. 34) on the inside of the table bracket is engaged with the teeth of the rack and the arrow stamped on the rack is pointing up.
- Slide the table bracket with the rack onto the column.
- Engage the bottom of the rack with the lip of the column support. Tighten the table bracket lock handle to lock the table bracket to the column.
- Install the rack ring (Ref. No. 37) on the column so the top lip of the rack sits into the rack ring.  
**IMPORTANT:** The bottom of the collar **MUST NOT** be pushed all the way down onto the top of the rack. **MAKE SURE** the top of the rack is under the bottom of the collar and that there is enough clearance to allow the rack to freely rotate around the column. Tighten the set screw of the rack ring.  
**NOTE:** To avoid column or collar damage, **DO NOT OVERTIGHTEN** the set screw.
- Install the table crank handle (Ref. No. 32) onto the worm gear shaft on the side of the table bracket.
- Line up the flat side of the worm gear shaft with the set screw in the table crank handle (Ref. No. 32) and tighten the screw with the 3 mm hex wrench provided.

**INSTALL THE HEAD**

Refer to Figure 9/10.

**WARNING:** Although compact, the drill press head assembly is heavy. Two people are required to mount the drill press head assembly onto the column.

- Carefully lift the head above the column and slide it onto the column. Make sure the head slides down over the column as far as possible. Align the head with the base.
- Using the 5 mm hex wrench, tighten the two head lock set screws (Ref. No. 70) on the right side of the head.

**INSTALL BELT TENSION HANDLE**

Refer to Figure 8.

- Thread handle (Ref. No. 183) into motor mount plate (Ref. No. 184).

**INSTALL FEED HANDLE ASSEMBLY**

Refer to Figure 8.

- Place key (Ref. No. 146) into feed shaft assembly (Ref. No. 62).
- Place quill feed handle assembly (Ref. No. 148) to the feed shaft assembly.
- Secure quill feed handle assembly with a flat head screw (Ref. No. 150) and a washer (Ref. No. 149).
- Thread handle bar (Ref. No. 151) into quill feed handle assembly (Ref. No. 148).

**INSTALL THE CHUCK**

Refer to Figure 8.

**WARNING:** Before any assembly of the chuck and arbor to the drill press head, clean all mating surfaces with a nonpetroleum based product; such as alcohol or lacquer thinner. Any oil or grease used in the packing of these parts must be removed otherwise the chuck may come loose during operation.

- Place the chuck (Ref. No. 133) onto the spindle arbor (Ref. No. 135) while lowering the spindle by turning the feed handles (Ref. No. 148) counterclockwise, until the slot appears on the quill.
- Push the chuck and spindle arbor up into the spindle, making sure the tang is engaged and locked in the inner slot of the spindle. Once tang is oriented correctly, drill duck will not rotate without turning the spindle.
- Open the jaws of the chuck (Ref. No. 133) by rotating the chuck sleeve clockwise. To prevent damage, make sure the jaws are completely retracted into the chuck.

**NOTE:** Clean the taper with a non-alcohol based cleaner before inserting it into the arbor.

- Using a rubber mallet, plastic-tipped hammer, or a block of wood and a hammer, firmly tap the chuck upward into position on the spindle shaft.

**CHUCK KEY STORAGE**

Refer to Figure 8, 9/10.

- Storage holder (Figure 9/10, Ref. No. 69) for the chuck key (Figure 8, Ref. No. 197) is located on the right side of the head.

**INSTALLATION****MOUNT DRILL PRESS**

- Drill press must be mounted to flat level surface. Use shims or machine mounts if necessary. Do not mount drill press in direct sunlight.
- Be sure to bolt drill press to floor or bench securely to prevent tipping and minimize vibration.
- Tighten all nuts and bolts that may have loosened during shipment.

**POWER SOURCE**

The motor is designed for operation on the voltage and frequency specified. Normal loads will be handled safely on voltages not more than 10% above or below the specified voltage.

Running the unit on voltages which are not within the range may cause overheating and motor burn out. Heavy loads require that the voltage at motor terminals be no less than the voltage specified.

**GROUNDING INSTRUCTIONS**

Refer to Figure 2, 3 and 4.

**WARNING:** Improper connection of equipment grounding conductor can result in the risk of electrical shock. Equipment should be grounded while in use to protect operator from electrical shock. Check with a qualified electrician if grounding instructions are not understood or if in doubt as to whether the tool is properly grounded.

This tool is equipped with an approved 3-conductor cord rated up to 300 V and a 3-prong grounding type plug rated at 115 V for your protection against shock hazards.

Grounding plug should be plugged directly into a properly installed and grounded 3-prong grounding-type receptacle, as shown (Figure 2).

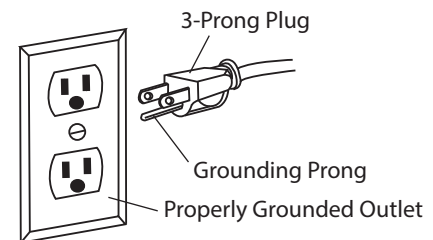

**Figure 2 – 3-Prong Receptacle**

Do not remove or alter grounding prong in any manner. In the event of a malfunction or breakdown, grounding provides a path of least resistance for electrical shock.

**WARNING:** Do not permit fingers to touch the terminals of plug when installing or removing from outlet.

Plug must be plugged into matching outlet that is properly installed and grounded in accordance with all local codes and ordinances. Do not modify plug provided. If it will not fit in outlet, have proper outlet installed by a qualified electrician.

Inspect tool cords periodically, and if damaged, have repaired by an authorized service facility.

Green (or green and yellow) conductor in cord is the grounding wire. If repair or replacement of the electric cord or plug is necessary, do not connect the green (or green and yellow) wire to a live terminal.

Where a 2-prong wall receptacle is encountered, it must be replaced with a properly grounded 3-prong receptacle installed in accordance with National Electric Code and local codes and ordinances.

**WARNING:** This work should be performed by a qualified electrician. A temporary 3-prong to 2-prong grounding adapter (See Figure 3) is available for connecting plugs to a two pole outlet if it is properly grounded.

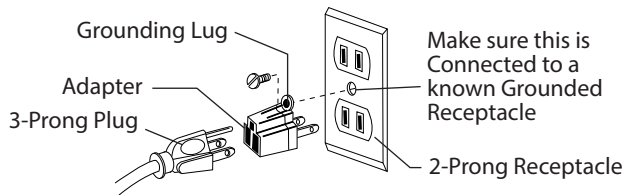

**Figure 3 – 2-Prong Receptacle with adapter**

Do not use a 3-prong to 2-prong grounding adapter unless permitted by local and national codes and ordinances.

(A 3-prong to 2-prong grounding adapter is not permitted in Canada.) Where permitted, the rigid green tab or terminal on the side of the adapter must be securely connected to a permanent electrical ground such as a properly grounded water pipe, a properly grounded outlet box or a properly grounded wire system.

Many cover plate screws, water pipes and outlet boxes are not properly grounded. To ensure proper ground, grounding means must be tested by a qualified electrician.

**EXTENSION CORDS**

- The use of any extension cord will cause some drop in voltage and loss of power.
- Wires of the extension cord must be of sufficient size to carry the current and maintain adequate voltage.
- Use the table to determine the minimum wire size (A.W.G.) extension cord.
- Use only 3-wire extension cords having 3-prong grounding type plugs and 3-pole receptacles which accept the tool plug.
- If the extension cord is worn, cut, or damaged in any way, replace it immediately.

**EXTENSION CORD LENGTH (120 VOLTS)**

Wire Size	A.W.G.
Up to 25 ft.....	14
25-50 ft.....	12

**NOTE:** Using extension cords over 50 ft. long is not recommended.

**EXTENSION CORD LENGTH (240 VOLTS)**

Wire Size	A.W.G.
Up to 50 ft.....	18
50-100 ft.....	16

**NOTE:** Using extension cords over 100 ft. long is not recommended.

**POWER SOURCE**

**For single phase:** Drill press requires a 120/240 volt, 60 Hz power source. To use the drill press with a 240 V power supply, have a qualified electrician attach a 240 volt, 20/30 A three-prong plug onto drill press line cord.

**For three phase:** Drill press requires a 120 volt, 60 Hz power source.

**ELECTRICAL CONNECTIONS**

Refer to Figure 4

**WARNING:** All electrical connections must be performed by a qualified electrician. Make sure unit is off and disconnected from power source while motor is mounted, connected, reconnected or anytime wiring is inspected.

- The motor should be wired for 120 volts and clockwise rotation as viewed from shaft end of motor.
- A label on the motor describes the possible wiring configurations. There are many different possible combinations, so only the diagram provided with the motor should be used.
- The power supply to motor is controlled by a push button switch. Power lines are connected to the quick connect terminals of the switch.
- The green ground line must remain securely fastened to the motor ground terminal to provide proper grounding.
- To operate drill press at 240 volts, rewire motor as shown in Figure 4 and replace line cord plug with a 240 volt, 15 A, 3-prong plug. If motor label has a different wiring configuration, use the motor label diagram to rewire motor.

**NOTE:** Only for the drill press with single phase use.

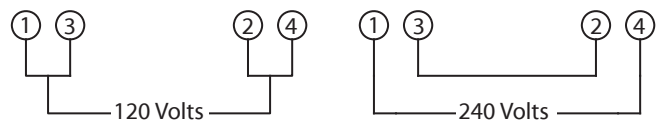

**Figure 4 – Wiring Schematic for Motor**

**OPERATION**

**WARNING:** Read and understand operating instructions and parts manual before operating this machine.

**CAUTION:** The operation of any power tool can result in foreign objects being thrown into the eyes, which can result in severe eye damage. Always wear safety glasses complying with United States ANSI Z87.1 (shown on package) before commencing power tool operation.

**START AND STOP THE DRILL PRESS**

Refer to Figure 9/10.

**WARNING:** Be sure drill bit is not in contact with workpiece when motor is started. Start motor and allow bit to come up to full speed before drilling.

- The ON/OFF switch (Ref. No. 48) is located on the front of the head casting.
- To turn the drill press on, push START button. Always allow drill bit to come up to speed before drilling.
- To turn the drill press off, press the large red OFF paddle or lift the paddle and press directly on the red OFF button. Do not leave drill press until the bit has come to a complete stop.

**SPEED ADJUSTMENTS**

Refer to Figures 5 and 8.

**WARNING:** Be sure drill press is turned off and is disconnected from power source before adjusting speeds.

- To change spindle speed, loosen motor lock handle (Ref. No. 187), pivot the motor toward front of drill press. This will loosen the belt and permit relocating the belt to the desired pulley groove for the required spindle speed (See Figure 5).
- After belt has been repositioned, pull the handle (Ref. No. 183) to move motor toward rear of drill press and tighten motor lock handle.
- Check belt for proper tension and make any final adjustment. A belt is properly tensioned when light pressure applied to midpoint of the belt produces about 1/2" deflection.

RPM	Belt Locaiton
120	A1-5Z
161	A1-4Y
231	B2-5Z
281	A1-3X
309	B2-4Y
424	C3-5Z
540	B2-3X
567	C3-4Y
596	A1-2W
622	D4-5Z
973	E5-4Y
1453	D4-3X
1699	E5-3X
2101	C3-2W
3083	D4-2W
3605	E5-2W

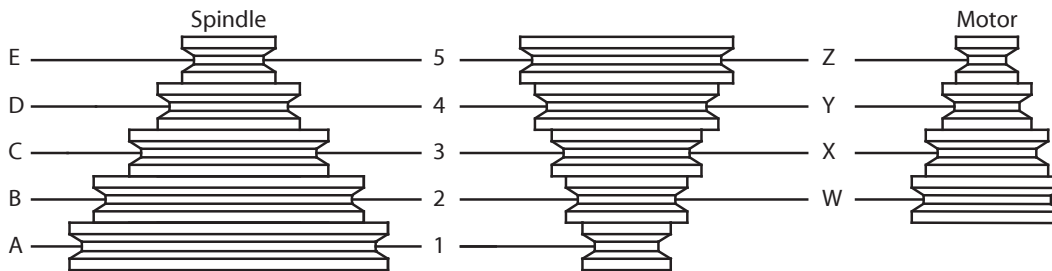

**Figure 5 – Spindle Speed Adjustment**

RPM	Wood		Zinc Diecast		Alum. & Brass		Plastic		Cast Iron & Bronze		Steel - Mild & Malleable		Steel - Cast & Med. Carbon		Steel - Stainless & Tool	
	in/mm		in/mm		in/mm		in/mm		in/mm		in/mm		in/mm		in/mm	
3605	5/16	7.9	3/16	4.8	11/64	4.4	5/32	4.0	7/64	2.8	3/32	2.4	1/16	1.6	1/32	0.8
2101	5/8	15.9	3/8	9.5	11/32	8.7	5/16	7.9	1/4	6.4	5/32	4.0	1/8	3.2	1/16	1.6
1699	3/4	19.0	7/16	11.1	13/32	10.3	3/8	9.5	5/16	7.9	3/16	4.8	1/8	3.2	1/16	1.6
1453	7/8	22.2	1/2	12.7	15/32	11.9	7/16	11.1	11/32	8.7	1/4	6.4	3/16	4.8	1/8	3.2
973	1	25.4	5/8	15.9	1/2	12.7	1/2	12.7	3/8	9.5	5/16	7.9	1/4	6.4	3/16	4.8
596	1 1/4	31.8	3/4	19.0	11/16	17.5	5/8	15.9	1/2	12.7	3/8	9.5	5/16	7.9	1/4	6.4
424	1 5/8	41.3	7/8	22.2	3/4	19.0	13/16	20.6	5/8	15.9	1/2	12.7	7/16	11.1	3/8	9.5
309	1 3/4	44.4	15/16	23.8	13/16	20.6	7/8	22.2	3/4	19.0	5/8	15.9	1/2	12.7	7/16	11.1
231	2	50.8	1	25.4	—	—	—	—	—	—	—	—	9/16	14.3	1/2	12.7

**TABLE ADJUSTMENTS**

Refer to Figure 7.

- Height adjustments: To adjust table, loosen locking handle (Ref. No. 33) and turn crank handle (Ref. No. 32) to desired height. Immediately retighten table bracket locking handle.
- Tilting work table: Loosen hex bolt (Ref. No. 21). Remove pin (Ref. No. 16) by loosening hex nut (Ref. No. 18). Tilt table to desired angle up to 45° and retighten table bolt. Reinsert pin and nut when returning the table to 0° position.
- To obtain more distance between chuck and table, the work table can be rotated 180° and base can be used as a work surface. This permits drilling of larger objects.
- Clamp table securely after adjustments have been made.

**DEPTH STOP ADJUSTMENT**

Refer to Figure 8.

To control drilling depth, use scale (Ref. No. 129) to adjust to desired depth. Depress and hold pin, slide depth stop nut (Ref. No. 130) along lead screw until bottom edge of nut coincides with the desired depth on the scale, then release pin. Use this feature to drill more than one hole to the same depth.

**MOUNT DRILL BIT**

Refer to Figure 8.

**WARNING:** To avoid injury or accident by the chuck key ejecting forcibly from the chuck when the power is turned on, use only the self-ejecting chuck key supplied with this drill press. ALWAYS recheck and remove the chuck key before turning the power on. Be sure drill press is turned off and is disconnected from power source before adjusting speeds.

- Place drill bit in jaws of drill chuck.
- Tighten chuck with drill chuck key. Be sure to tighten the chuck using all three key positions on the chuck body and remove chuck key.
- Use only the self-ejecting chuck key (Ref. No. 197) supplied with this drill press, or a duplicate key. Use of any other key might allow start up with the key still in the chuck. An airborne key could strike the operator and cause injury.



**REMOVE THE CHUCK**

Refer to Figure 8.

- With the switch "OFF" and the unit unplugged, adjust the depth stop nut (Ref. No. 130) to hold the drill at a depth of 3 in. (7.6 cm).
- Align the key holes in the spindle and quill by rotating the chuck by hand.
- Insert the key wedge (Ref. No. 142) into the key holes. Tap the key wedge lightly with a plastic tipped hammer, until the chuck and arbor fall out of the spindle.

**NOTE:** Place one hand below the chuck to catch it when it falls out.

**DIGITAL DISPLAY PANEL**

Refer to Figure 6.

- Display panel (A) shows the spindle RPM.
- Button (B) turns power on and off to LED light.

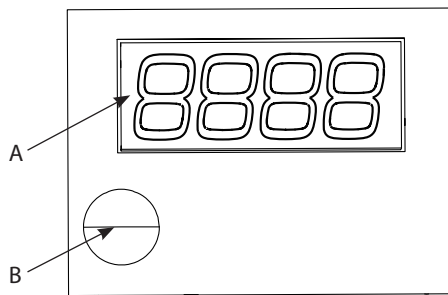

**Figure 6 – Digital Display Panel**

**REVERSING SWITCH**

Refer to Figure 10.

**NOTE:** Only the drill press with the three-phase electric power system has the reversible function.

- The direction of the chuck rotation is controlled by the rocker switch located at the left side of the ON/OFF switch base (Ref. No. 53).

**WARNING:** The design of the switch will not permit changing the direction of rotation while the drill press is running.

## MAINTENANCE

**WARNING:** Turn switch off and remove plug from power source outlet before maintaining or lubricating your drill press

**DRIVE BELT**

Replace drive belt when worn.

**LUBRICATION**

Refer to Figures 7 and 8.

The ball bearings are lubricated at the factory and need no further lubrication. Using 20 wt. non detergent oil, periodically lubricate the splines (grooves) in the spindle and the rack (teeth on the quill) as follows:

- Lower quill assembly (Figure 8, Ref. No. 148) all the way down.
- Apply lubricant around the inside of the hole in the spindle pulley (Figure 8, Ref. Nos. 159 & 173).
- Apply lubricant to rack (teeth) on quill (Figure 8, Ref. No. 145) while extended below drill press head.

- Apply lubricant to rack and pinion gear (Figure 7, Ref. Nos. 14 & 34) on column and table assembly.

**CLEAN MOTOR**

Frequently blow out any dust that may accumulate inside motor. If power cord is worn, cut or damaged in any way, have it replaced immediately.

**IMPORTANT:** To assure product SAFETY and RELIABILITY, repairs, maintenance and adjustment (other than those listed in this manual) should be performed by authorized service centers or other qualified service organizations, always using identical replacement parts.

**WARNING:** To avoid shock or fire hazard, if the power lead is worn or cut in any way, replace it immediately.

## TROUBLESHOOTING

SYMPTOM	POSSIBLE CAUSES	CORRECTIVE ACTION
Spindle does not turn	1. No power to drill press	1. Check wiring, fuse or circuit breaker
	2. Defective switch	2. Replace switch
	3. Defective motor	3. Replace motor
Noisy spindle	Defective bearings	Replace bearings
Noisy operation	1. Incorrect belt tension	1. Adjust tension
	2. Dry spindle	2. Lubricate spindle, See Lubrication, page 7
	3. Loose spindle	3. Tighten pulley nut
	4. Loose motor pulley	4. Tighten set screw in pulley
Bit burns or smokes	1. Incorrect speed	1. Change speed
	2. Chips not coming out of table	2. Retract bit frequently to clear chips
	3. Dull bit	3. Sharpen or replace bit
	4. Feeding too slow	4. Feed faster; enough to allow drill to cut
	5. Bit not lubricated	5. Lubricate bit
	6. Bit running backwards	6. Check motor rotation to be sure it is clockwise facing shaft end
Excessive drill runout or wobble	1. Bent bit	1. Replace bit
	2. Bit not properly installed in chuck	2. Install bit properly
	3. Chuck not properly installed	3. Install chuck properly
	4. Worn spindle bearings	4. Replace bearings
Drill bit binds in workpiece	1. Workpiece pinching bit or excessive feed	1. Support or clamp work, decrease feed pressure
	2. Improper belt tension	2. Adjust tension
	3. Workpiece not supported or clamped properly	3. Support or clamp workpiece securely





**NOTES**

**NOTES**

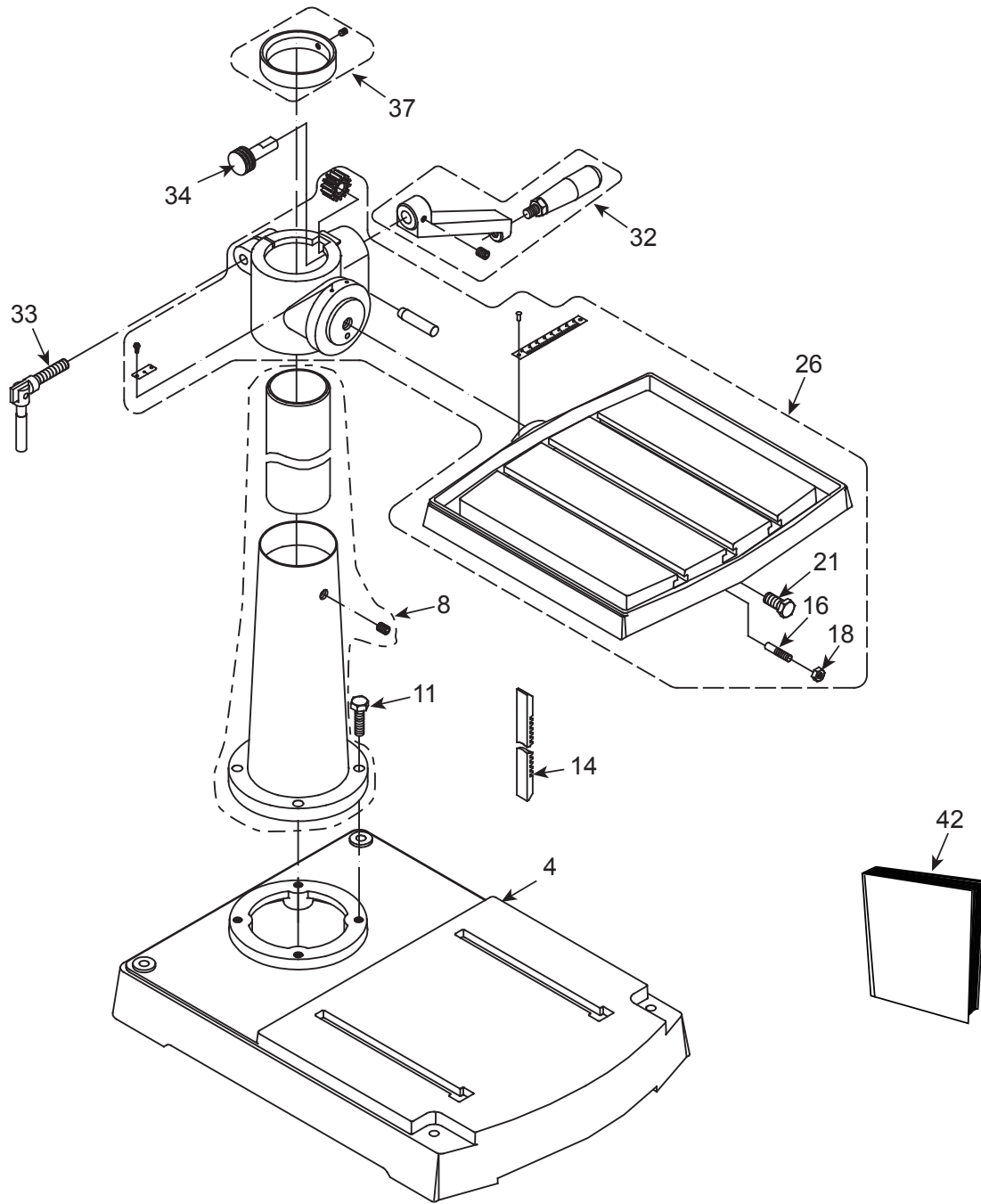

Figure 7 - Replacement Parts Illustration for Base (Single & Three Phase)

## REPLACEMENT PARTS LIST FOR BASE (SINGLE & THREE PHASE)

Ref. No.	Description	Part No.	Qty.
4	Base	9631635.05	1
8	Column holder ass'y	9631958.05	1
11	M12*1.75-40 Hex. hd. bolt	*	4
14	Rack	9631959.05	1
16	Location pin	9631972.05	1
18	1/4*20UNC T=4.7 Hex. nut	*	1
21	5/8-11UNC-2 Hex. hd. bolt	*	1
26	Table ass'y	9631973.05	1
32	Crank handle ass'y	9632125.10	1
33	Column lock handle	9631976.05	1
34	Worm	9632123.05	1
37	Rack ring ass'y	9631978.05	1
42	Instruction manual	*	1

\* Standard hardware item available locally.

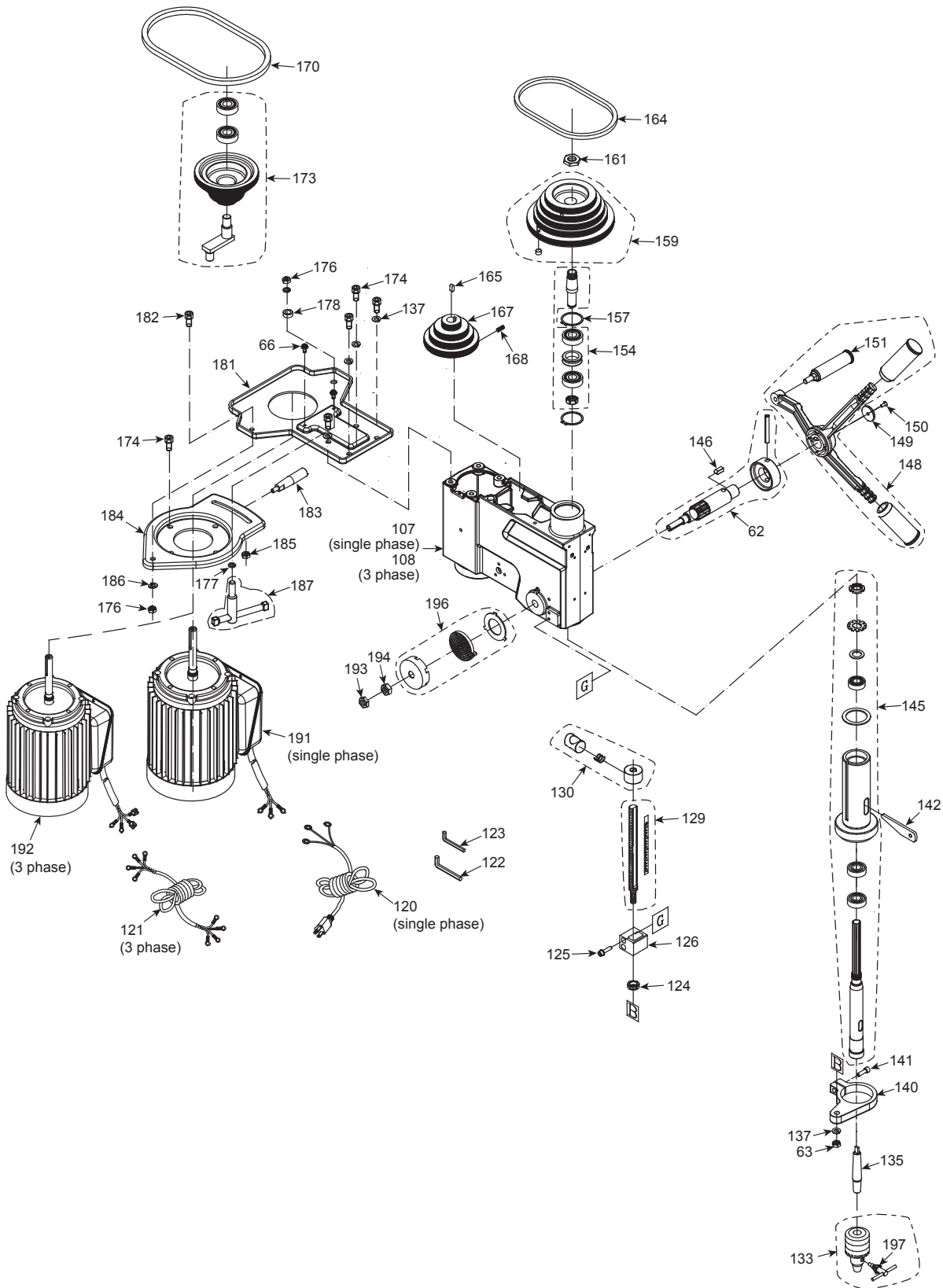

Figure 8 - Replacement Parts Illustration for Spindle and Drive (Single & Three Phase)

## REPLACEMENT PARTS LIST FOR SPINDLE AND DRIVE (SINGLE & THREE PHASE)

Ref. No.	Description	Part No.	Qty.	Ref. No.	Description	Part No.	Qty.
62	Feed shaft ass'y	9632021.05	1	157	Retaining ring	9632129.15	2
63	M10*1.5 T=8 Hex. nut	*	1	159	Pulley & magnet ass'y	9632127.10	1
66	M6*1.0-12 Cr. re. round washer hd. screw	*	6	161	Pulley set nut	9632126.10	1
107	Head for single phase	*	1	164	V-ribbed belt (poiyourethane)	9632180.15	1
108	Head for three phase	*	1	165	Parallel key	9607885.05	1
120	Power cable for single phase	9632016.05	1	167	Motor pulley	9632151.10	1
121	Power cable for three phase	9632016.10	1	168	M6*1.0-16 Hex. soc. set screw	*	1
122	5 mm Hex. wrench	9600150.05	1	170	V-ribbed belt (poiyourethane)	9632182.10	1
123	3 mm Hex. wrench	9600149.05	1	173	Pulley ass'y	9632132.15	1
124	Circular nut	9632066.05	1	174	M10*1.5-20 Hex. soc. hd. cap bolt	*	8
125	M6*1.0-40 Hex. soc. hd. cap screw	*	2	176	M10*1.5 T=10 Chuck nut	*	2
126	Plunger housing	9632067.05	1	177	φ10*20-2 Nylon washer	*	2
129	Set bolt ass'y	9632026.15	1	178	Collar	9600533.05	1
130	Locking ring	9632029.05	1	181	Motor retaining clip	9632184.10	1
133	Chuck & key	9632138.10	1	182	M10*1.5-25 Hex. soc. hd. cap bolt	*	1
135	Drilling arbor	9627926.10	1	183	Handle shifter	9632148.05	1
137	Φ10 Spring washer	*	5	184	Motor bracket	9632149.05	1
140	Set ring	9632136.15	1	185	M10*1.5 T=8 Hex. nut	*	1
141	M8*1.25-20 Hex. soc. hd. cap bolt	*	1	186	Φ12 Spring washer	*	1
142	Wedge shifter	9618909.05	1	187	Locking handle ass'y	9632145.05	1
145	Spindle ass'y	9632137.15	1	191	Motor ass'y for single phase	9632181.20	1
146	Parallel key	9632020.05	1	192	Motor ass'y for three phase	9632181.25	1
148	Handle ass'y	9632141.10	1	193	1/2*20UNF T=6.5 Hex. nut	*	1
149	Washer	9632017.05	1	194	1/2*20UNF T=10 Hex. nut	*	1
150	M5*0.8-12 Cr. re. count hd. screw	9632004.05	1	196	Spring cap ass'y	9632133.10	1
151	Handle bar ass'y	9632018.05	1	197	Chuck key	9632139.10	1
154	Driving sleeve ass'y	9609624.15	1				

\* Standard hardware item available locally.





## REPLACEMENT PARTS LIST FOR HEAD (SINGLE PHASE)

Ref. No.	Description	Part No.	Qty.	Ref. No.	Description	Part No.	Qty.
43	Lead wire ass'y	9600068.00	1	81	Strain relief	9632041.05	1
44	Lead wire ass'y	9600069.00	1	85	Hall sensor ass'y	9632042.05	1
45	Lead wire ass'y	9600070.00	1	86	M3*0.5-8 Cr. re. pan hd. screw	*	2
48	Switch ass'y	9632044.05	1	87	M8*1.25 T=5 Hex. nut	*	1
49	M5*0.8-35 Cr. re. pan hd. screw	*	2	88	Captive screw	9632037.05	1
52	Switch box ass'y	9632045.05	1	90	Caution label	*	1
54	Controller ass'y	9632160.05	1	92	Label	*	1
55	M3*24-6 Cr. re. pan hd. tapping screw	*	4	93	Warning label	*	1
56	M5*0.8-16 Cr. re. round washer hd. screw	*	2	94	M5*0.8-10 Cr. re. pan hd. screw	*	1
57	M5*0.8-8 Cr. re. pan hd. screw	*	2	95	Clamp cord	9632156.05	1
58	φ5 External tooth lock washer	*	2	97	Spring pin	9604092.10	2
59	Sticker	*	2	99	Lamp socket	9632058.05	1
62	Feed shaft ass'y	9632021.05	1	100	M5*0.8-16 Hex. soc. hd. cap screw	*	3
63	M10*1.5 T=8 Hex. nut	*	1	101	Lamp ass'y	9632064.05	1
65	Quill set screw	9632135.05	1	103	Plate cover	9632065.10	1
67	M6*1.0-16 Cr. re. pan hd. screw	*	1	107	Head	*	1
69	Chuck key holder	9632158.10	1	198	Motor label	*	1
70	M10*1.5-12 Hex. soc. set screw	*	2	199	Scale plate	9632043.06	1
71	φ8.5*22-3 Flat washer	*	4	200	Label	*	1
76	M4*0.7-6 Cr. re. pan hd. screw	*	1	201	φ2.3-5 Drive screw	*	4
80	Pulley cover ass'y	9632038.05	1	202	M4*16-20 Cr. re. truss hd. tapping screw	*	2

\* Standard hardware item available locally.

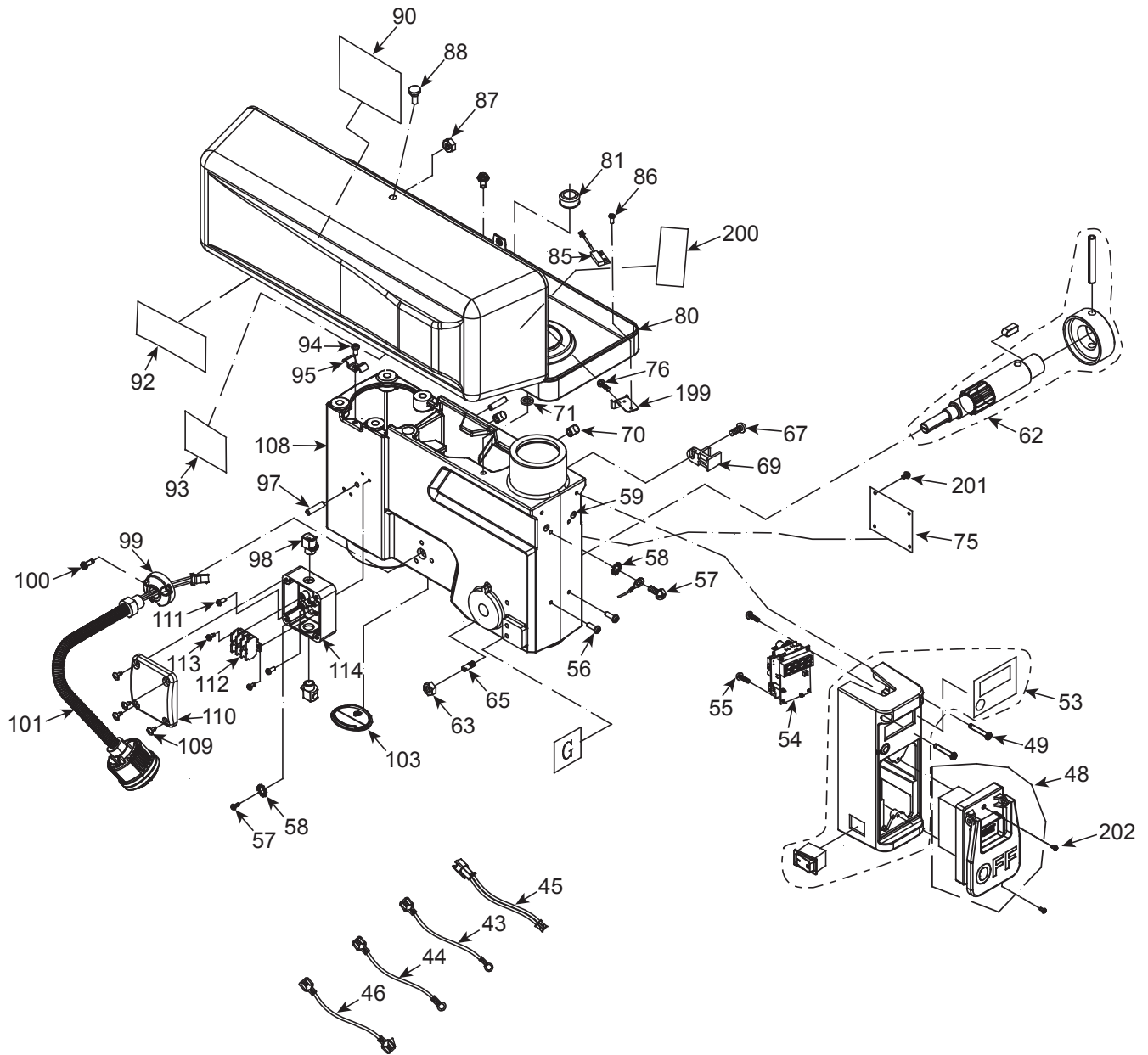

Figure 10 - Replacement Parts Illustration for Head (Three Phase)

## REPLACEMENT PARTS LIST FOR HEAD (THREE PHASE)

Ref. No.	Description	Part No.	Qty.	Ref. No.	Description	Part No.	Qty.
43	Lead wire ass'y	9600068.00	2	86	M3*0.5-8 Cr. re. pan hd. screw	*	2
44	Lead wire ass'y	9600069.00	2	87	M8*1.25 T=5 Hex. nut	*	1
45	Lead wire ass'y	9600070.00	1	88	Captive screw	9632037.05	1
46	Lead wire ass'y	9600071.00	2	90	Caution label	*	1
48	Switch ass'y	9632044.05	1	92	Label	*	1
49	M5*0.8-35 Cr. re. pan hd. screw	*	2	93	Warning label	*	1
53	Switch box ass'y	9632045.10	1	94	M5*0.8-10 Cr. re. pan hd. screw	*	1
54	Controller ass'y	9632160.05	1	95	Clamp cord	9632156.05	1
55	M3*24-6 Cr. re. pan hd. tapping screw	*	4	97	Spring pin	9604092.10	2
56	M5*0.8-16 Cr. re. round washer hd. screw	*	2	98	Strain relief	9632044.05	2
57	M5*0.8-8 Cr. re. pan hd. screw	*	2	99	Lamp socket	9632058.05	1
58	φ5 External tooth lock washer	*	2	100	M5*0.8-16 Hex. soc. hd. cap screw	*	3
59	Sticker	*	2	101	Lamp ass'y	9632064.05	1
62	Feed shaft ass'y	9632021.05	1	103	Plate cover	9632065.10	1
63	M10*1.5 T=8 Hex. nut	*	1	108	Head	*	1
65	Quill set screw	9632135.05	1	109	M5*12-16 Cr. re. truss hd. tapping screw	*	4
67	M6*1.0-16 Cr. re. pan hd. screw	*	1	110	Switch cover	9632048.05	1
69	Chuck key holder	9632158.10	1	111	M5*0.8-12 Cr. re. pan hd. screw	*	2
70	M10*1.5-12 Hex. soc. set screw	*	2	112	Wire connector	9632047.05	1
71	φ8.5*22-3 Flat washer	*	4	113	M4*16-10 Cr. re. pan hd. tapping screw	*	2
75	Motor label	*	1	114	Connector box	9631089.05	1
76	M4*0.7-6 Cr. re. pan hd. screw	*	1	199	Scale plate	9632043.06	1
80	Pulley cover ass'y	9632038.05	1	200	Label	*	1
81	Strain relief	9632041.05	1	201	φ2.3-5 Drive screw	*	4
85	Hall sensor ass'y	9632042.05	1	202	M4*16-20 Cr. re. truss hd. tapping screw	*	2

\* Standard hardware item available locally.

## WARRANTY

Palmgren warrants their products to be free of defects in material or workmanship. This warranty does not cover defects due directly or indirectly to misuse, abuse, normal wear and tear, failure to properly maintain the product, heated, ground or otherwise altered, or used for a purpose other than that for which it was intended. The warranty does not cover expendable and/or wear parts (i.e. v-belts, coated screws, abrasives), damage to tools arising from alteration, abuse or use other than their intended purpose, packing and freight. The duration of this warranty is expressly limited to one year parts and labor, unless otherwise noted below beginning from the date of delivery to the original user. The Palmgren products carry the following warranties on parts with a 1 year warranty on labor:

- USA Machine vises – Lifetime
- IQ Machine vises – Lifetime
- Bench vises – Lifetime
- Positioning tables – Lifetime
- Bench grinders & buffers – 3 years
- Tapping machines – 2 years
- Drilling machines – 2 years
- Finishing machines – 2 years
- Band saws – 2 years
- Work stands – 2 years
- Arbor presses – 2 years
- Metal framing equipment – 2 years
- Accessories – 1 year

The obligation of Palmgren is limited solely to the repair or replacement, at our option, at its factory or authorized repair agent of any part that should prove deficient. Purchaser must lubricate and maintain the product under normal operating conditions at all times. Prior to operation become familiar with product and the included materials, i.e. warnings, cautions and manuals. **Failure to follow these instructions will void the warranty.**

This warranty is the purchaser's exclusive remedy against Palmgren for any deficiency in its products. Under no circumstances is Palmgren liable for any direct, indirect, incidental, special or consequential damages including lost profits in any way related to the use or inability to use our products. This warranty gives you specific legal rights which may vary from state to state.

### SERVICE & REPAIR

1. If a Palmgren product requires a repair or warranty service **DO NOT** return the product to the place of purchase.
2. All warranty related work must be evaluated and approved by Palmgren.
3. Prior to returning any item the user must obtain factory approval and a valid RGA number.
4. For instructions and RGA number call toll free (800) 621-6145.