

PALMGREN

BENCH GRINDER PEDESTAL STAND

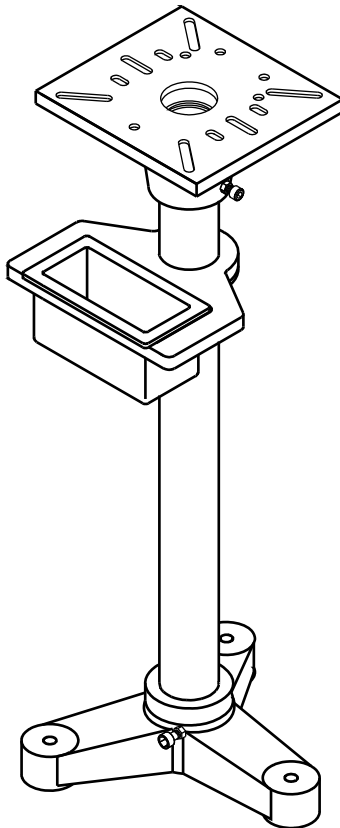

Read carefully and follow all safety rules and operating instructions before first use of this product.

DESCRIPTION

Palmgren Bench Grinder Pedestal Stand is constructed of heavy cast iron and steel and is designed for use with most bench grinders. The cast iron top is provided with slots and holes for securely mounting a bench grinder. A water pot is provided for quenching workpiece after grinding.

DIMENSIONS

Refer to Figure 1.

Stock No.	70101B	
Base Length	L	16 ¹ / ₄ "
Base Width	W	14 ¹ / ₂ "
Height Range	H	32 ⁹ / ₁₆ "
Top Length	A	10 ⁵ / ₈ "
Top Width	B	10 ⁵ / ₈ "

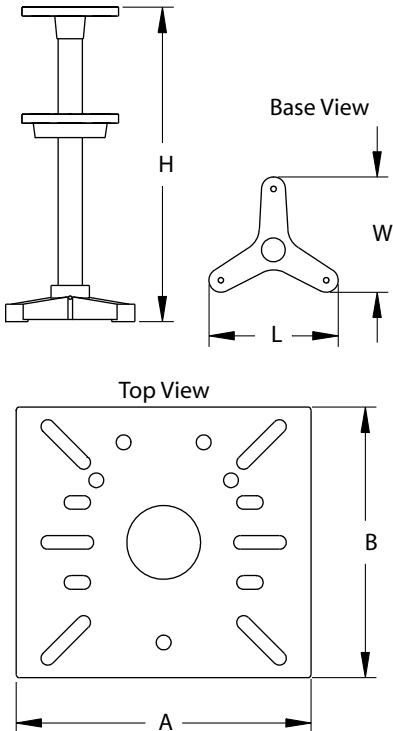

ASSEMBLY

Refer to Figure 2.

- Slide column into base (Ref. Nos. 2 and 3); secure by tightening hex head bolts (Ref. No. 6) against column. Tighten hex nuts (Ref. No. 7) against base to secure bolts.
- Slide water pot holder (Ref. No. 4) over column. Tighten hex head bolt and nut (Ref. Nos. 6 and 7) to secure holder.
- Slide top (Ref. No. 1) over column and secure with bolt and nut (Ref. Nos. 6 and 7).
- Slide water pot (Ref. No. 5) into holder. Adjust pot holder height as required.
- Secure base to floor for maximum stability and safety. (Hardware not included.)

Figure 1 - Dimensions

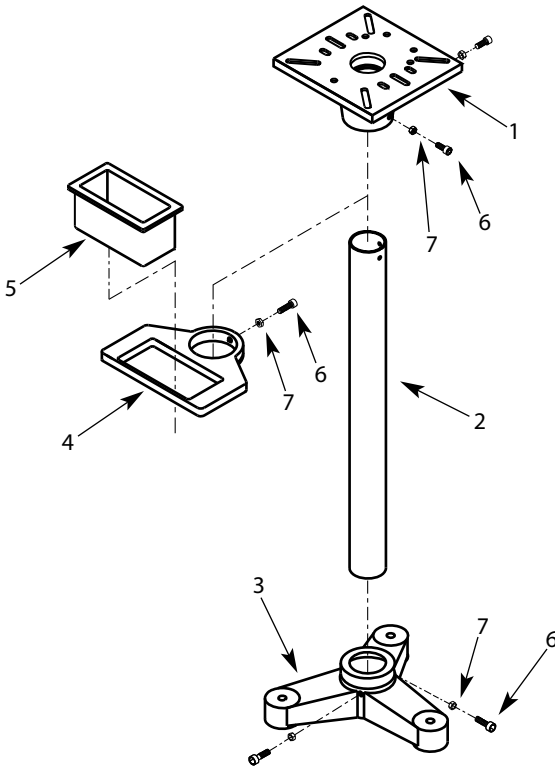

Figure 2 - Replacement Parts Illustration for Bench Grinder Pedestal Stand

**REPLACEMENT PARTS LIST FOR
BENCH GRINDER PEDESTAL STAND**

Ref. No.	Description	Part Number for: 70101B	Qty.
1	Top	32585.00	1
2	Column	32586.00	1
3	Base	32587.00	1
4	Water Pot Holder	32588.00	1
5	Water Pot	32589.00	1
6	10-1.5 x 30mm Socket Head Bolt	*	5
7	10-1.5 Hex Nut	*	5
Δ	Operator's Manual	32591.09	1

Δ Not shown.

* Standard hardware item available locally.

BASE DE LA PLATAFORMA PARA ESMERILADORAS DE BANCO

NO. DE EXISTENCIA 70101B

Antes de utilizar este producto por primera vez, lea cuidadosamente todas las normas de seguridad y las instrucciones de operación y cumpla con las mismas.

DESCRIPCION

La Base de la Plataforma para Esmeriladoras de Banco Palmgren ha sido fabricada de hierro fundido y acero pesados, y diseñada para usarse con la mayoría de las esmeriladoras de banco. La parte superior de hierro fundido viene con ranuras y agujeros para montar la esmeriladora de banco en forma segura. Se proporciona un contenedor de agua para sumergir la pieza de trabajo después de esmerilar.

DIMENSIONES

Refiérase a la Figura 1.

No. de Existencia		70101B
Longitud de la Base	L	412 mm
Ancho de la Base	W	368 mm
Extensión de la Altura	H	827 mm
Longitud de la Parte Superior	A	270 mm
Ancho de la Parte Superior	B	270 mm



Figura 1 - Dimensiones

MONTAJE

Refiérase a la Figura 2.

- Deslice la columna en la base (Ref. Nos. 2 y 3); asegúrela apretando los pernos de cabeza hexagonal (Ref. No. 6) contra la columna. Apriete las tuercas hexagonales (Ref. No. 7) contra la base para asegurar los pernos.
- Deslice el sujetador del contenedor de agua (Ref. No. 4) sobre la columna. Apriete el perno de cabeza hexagonal y la tuerca (Ref. Nos. 6 y 7) para asegurar el sujetador.
- Deslice la parte superior (Ref. No. 1) sobre la columna y asegúrela con el perno y la tuerca (Ref. Nos. 6 y 7).
- Deslice el contenedor de agua (Ref. No. 5) en el sujetador. Ajuste la altura del sujetador de agua según sea necesario.
- Asegure la base al piso para lograr una estabilidad y una seguridad máximas. (Los artículos de ferretería no vienen incluidos.)

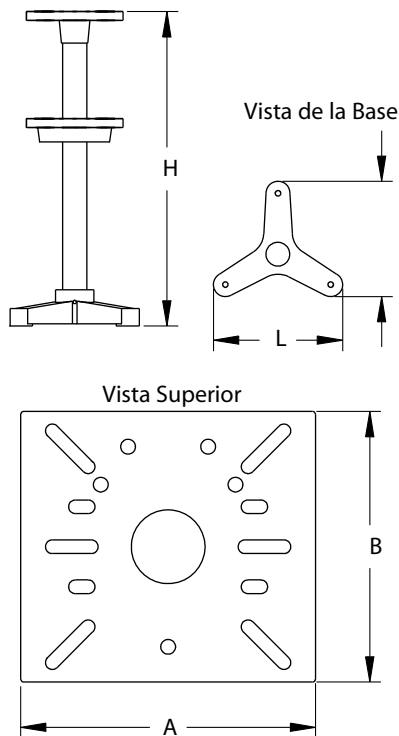
NOTAS

NOTAS

WARRANTY

Palmgren warrants their products to be free of defects in material or workmanship. This warranty does not cover defects due directly or indirectly to misuse, abuse, normal wear and tear, failure to properly maintain the product, heated, ground or otherwise altered, or used for a purpose other than that for which it was intended. The warranty does not cover expendable and/or wear parts (i.e. v-belts, coated screws, abrasives), damage to tools arising from alteration, abuse or use other than their intended purpose, packing and freight. The duration of this warranty is expressly limited to one year parts and labor, unless otherwise noted below beginning from the date of delivery to the original user. The Palmgren products carry the following warranties on parts with a 1 year warranty on labor:

- USA Machine vises – Lifetime
- IQ Machine vises – Lifetime
- Bench vises – Lifetime
- Positioning tables – Lifetime
- Bench grinders & buffers – 3 years
- Tapping machines – 2 years
- Drilling machines – 2 years
- Finishing machines – 2 years
- Band saws – 2 years
- Work stands – 2 years
- Arbor Presses – 2 years
- Metal Framing Equipment – 2 years
- Accessories – 1 year

The obligation of Palmgren is limited solely to the repair or replacement, at our option, at its factory or authorized repair agent of any part that should prove deficient. Purchaser must lubricate and maintain the product under normal operating conditions at all times. Prior to operation become familiar with product and the included materials, i.e. warnings, cautions and manuals. **Failure to follow these instructions will void the warranty.**

This warranty is the purchaser's exclusive remedy against Palmgren for any deficiency in its products. Under no circumstances is Palmgren liable for any direct, indirect, incidental, special or consequential damages including lost profits in any way related to the use or inability to use our products. This warranty gives you specific legal rights which may vary from state to state.

SERVICE & REPAIR

1. If a Palmgren product requires a repair or warranty service **DO NOT** return the product to the place of purchase.
2. All warranty related work must be evaluated and approved by Palmgren.
3. Prior to returning any item the user must obtain factory approval and a valid RGA number.
4. For instructions and RGA number call toll free (800) 621-6145.

The logo for Palmgren, featuring the word "PALMGREN" in a bold, black, sans-serif font. The letter "A" is stylized with a small triangle pointing upwards inside it.