

# Topper Units

306556S

EN

**Grease dispense unit with pneumatic pump elevator for easy drum replacement. For professional use only.**

## Model 226013

50:1 Ratio Fire-Ball<sup>®</sup> Pump  
5000 psi (34.5 MPa, 345 bar) Maximum Working Pressure  
100 PSI (0.68 MPa, 6.89 bar) Maximum Air Pressure

## Model 226018

50:1 Ratio President<sup>®</sup> Pump  
4000 psi (27.6 MPa, 276 bar) Maximum Working Pressure  
80 PSI (0.55 MPa, 5.5 bar) Maximum Air Pressure

## Model 244637

75:1 Ratio President<sup>®</sup> Pump  
4000 psi (27.6 MPa, 276 bar) Maximum Working Pressure  
80 PSI (0.55 MPa, 5.5 bar) Maximum Air Pressure

## Model 204490, Elevator and Inductor

without pump or hose kit



### Important Safety Instructions

Read all warnings and instructions in this manual. Save these instructions.

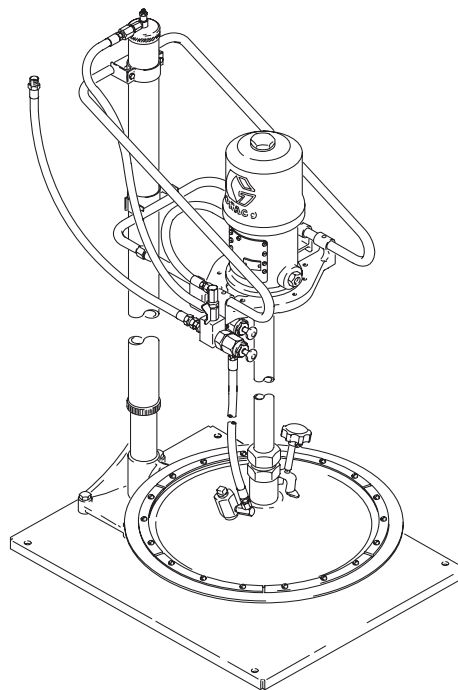









# Contents

- Warnings** ..... **3**
- Installation** ..... **5**
  - Grounding ..... 5
  - Pressure Relief Procedure ..... 5
  - Typical Installation ..... 6
- Operation** ..... **10**
  - Installing a Drum ..... 10
  - Removing a Drum ..... 11
- Maintenance** ..... **12**
  - Removing the Pump ..... 12
  - Reinstalling the Pump ..... 12
- Troubleshooting** ..... **13**
- Parts** ..... **14**
- Technical Data** ..... **19**
- Graco Standard Warranty** ..... **20**

# Warnings

The following warnings are for the setup, use, grounding, maintenance, and repair of this equipment. The exclamation point symbol alerts you to a general warning and the hazard symbols refer to procedure-specific risks. When these symbols appear in the body of this manual or on warning labels, refer back to these Warnings. Product-specific hazard symbols and warnings not covered in this section may appear throughout the body of this manual where applicable.

 <b>WARNING</b>	
	<p><b>FIRE AND EXPLOSION HAZARD</b></p> <p>When flammable fluids are present in the work area, such as gasoline and windshield wiper fluid, be aware that flammable fumes can ignite or explode. To help prevent fire and explosion:</p> <ul style="list-style-type: none"> <li>• Use equipment only in well ventilated area.</li> <li>• Eliminate all ignition sources, such as cigarettes and portable electric lamps.</li> <li>• Keep work area free of debris, including rags and spilled or open containers of solvent and gasoline.</li> <li>• Do not plug or unplug power cords or turn lights on or off when flammable fumes are present.</li> <li>• Ground all equipment in the work area.</li> <li>• Use only grounded hoses.</li> <li>• If there is static sparking or you feel a shock, <b>stop operation immediately</b>. Do not use equipment until you identify and correct the problem.</li> <li>• Keep a working fire extinguisher in the work area.</li> </ul>
	<p><b>EQUIPMENT MISUSE HAZARD</b></p> <p>Misuse can cause death or serious injury.</p> <ul style="list-style-type: none"> <li>• Do not operate the unit when fatigued or under the influence of drugs or alcohol.</li> <li>• Do not exceed the maximum working pressure or temperature rating of the lowest rated system component. See <b>Technical Data</b> in all equipment manuals.</li> <li>• Use fluids and solvents that are compatible with equipment wetted parts. See <b>Technical Data</b> in all equipment manuals. Read fluid and solvent manufacturer's warnings. For complete information about your material, request MSDS forms from distributor or retailer.</li> <li>• Check equipment daily. Repair or replace worn or damaged parts immediately with genuine manufacturer's replacement parts only.</li> <li>• Do not alter or modify equipment.</li> <li>• Use equipment only for its intended purpose. Call your distributor for information.</li> <li>• Route hoses and cables away from traffic areas, sharp edges, moving parts, and hot surfaces.</li> <li>• Do not kink or over bend hoses or use hoses to pull equipment.</li> <li>• Keep children and animals away from work area.</li> <li>• Comply with all applicable safety regulations.</li> </ul>
	<p><b>SKIN INJECTION HAZARD</b></p> <p>High-pressure fluid from dispense valve, hose leaks, or ruptured components will pierce skin. This may look like just a cut, but it is a serious injury that can result in amputation. <b>Get immediate surgical treatment.</b></p> <ul style="list-style-type: none"> <li>• Do not point dispense valve at anyone or at any part of the body.</li> <li>• Do not put your hand over the end of the dispense nozzle.</li> <li>• Do not stop or deflect leaks with your hand, body, glove, or rag.</li> <li>• Follow <b>Pressure Relief Procedure</b> in this manual, when you stop spraying and before cleaning, checking, or servicing equipment.</li> </ul>

 <b>WARNING</b>	
	<p><b>TOXIC FLUID HAZARD</b></p> <p>Hazardous fluid or toxic fumes can cause serious injury or death if splashed in the eyes or on the skin, inhaled, or swallowed.</p> <ul style="list-style-type: none"> <li>• Know the specific hazards of the fluid you are using.</li> <li>• Store hazardous fluid in an approved container. Dispose of hazardous fluid according to all local, state, and national guidelines.</li> <li>• Always wear protective eye wear, gloves, clothing, and respirator as recommended by the fluid and solvent manufacturer.</li> </ul>
 	<p><b>MOVING PARTS HAZARD</b></p> <p>Moving parts can pinch or amputate fingers and other body parts.</p> <ul style="list-style-type: none"> <li>• Keep clear of moving parts.</li> <li>• Do not operate equipment with protective guards or covers removed.</li> <li>• Pressurized equipment can start without warning. Before checking, moving, or servicing equipment, follow the <b>Pressure Relief Procedure</b> in this manual. Disconnect power or air supply.</li> </ul>
	<p><b>PERSONAL PROTECTIVE EQUIPMENT</b></p> <p>You must wear appropriate protective equipment when operating, servicing, or when in the operating area of the equipment to help protect you from serious injury, including eye injury, hearing loss, inhalation of toxic fumes, and burns. This equipment includes but is not limited to:</p> <ul style="list-style-type: none"> <li>• Protective eyewear, and hearing protection.</li> <li>• Respirators, protective clothing, and gloves as recommended by the fluid and solvent manufacturer.</li> </ul>

# Installation

## Grounding

--	--	--	--	--	--	--

The equipment must be grounded to reduce the risk of static sparking and electric shock. Electric or static sparking can cause fumes to ignite or explode. Improper grounding can cause electric shock. Grounding provides an escape wire for the electric current.

- *Pump:* Use a ground wire and clamp as shown in Fig 1.
- *Air and fluid hoses:* Use only electrically conductive hoses.
- *Air Compressor:* Follow manufacturer's recommendations.
- *Spray gun and dispensing valve:* Ground through connection to a properly grounded fluid hose and pump.
- *Fluid supply container:* Follow your local code.
- *Truck bed or platform:* Follow your local code.
- *Solvent pails used when flushing:* Follow your local code. Use only metal pails, which are conductive, placed on a grounded surface. Do not place the pail on a nonconductive surface, such as paper or cardboard, which interrupts the grounding continuity.
- *To maintain grounding continuity when flushing or relieving pressure:* Hold a metal part of the dispensing valve firmly to the side of a grounded *metal* pail, then trigger the valve.

### Grounding the Pump

1. Remove the ground screw (Z) and insert through the eye of the ring terminal at the end of ground wire (Y).
2. Fasten the ground screw back into the pump and tighten securely.

3. Connect the other end of the ground wire to a true earth ground. (Fig 1).

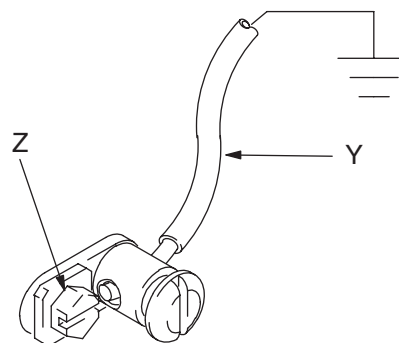

FIG. 1

## Pressure Relief Procedure



Follow the Pressure Relief Procedure whenever you see this symbol.

--	--	--	--	--	--	--

This equipment stays pressurized until pressure is manually relieved. To help prevent serious injury from pressurized fluid, such as skin injection, splashing fluid and moving parts, follow the Pressure Relief Procedure when you stop spraying and before cleaning, checking, or servicing the equipment.

1. Close the pump's air regulator.
2. Close the supply pump's bleed-type master air valve (required in this system).
3. Hold a metal part of the dispensing valve firmly to a grounded metal waste container and open the dispensing valve until pressure is fully relieved.

*If you suspect that the dispensing valve, extension, or grease fitting coupler is clogged, or that pressure has not been fully relieved after following the steps above, **VERY SLOWLY** loosen the coupler or hose end coupling and relieve pressure gradually, then loosen completely and clear the clog.*

## Typical Installation

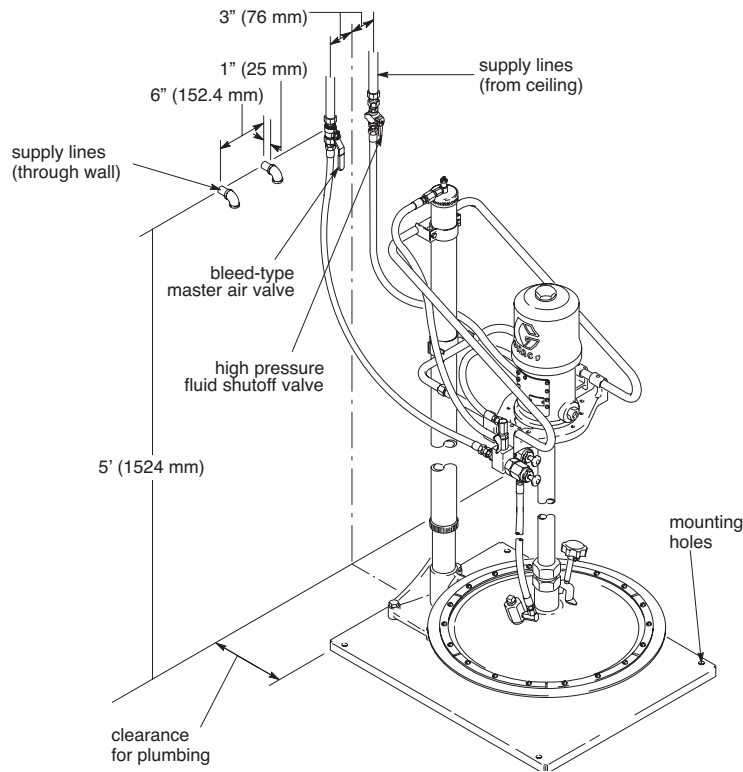

FIG. 2

The Typical Installation (shown in fig 2) is only a guide for selecting and installing this system. It is not an actual system design. Contact your local Graco representative for assistance in designing a system to suit your particular needs.

### Positioning the Elevator

1. Position the elevator where the ceiling is at least 8 ft (2.6 m) high. The elevator is 90 in (2.4 m) when fully raised.
2. Provide adequate space in front of the elevator for changing drums and in back and on the side for plumbing.

### Mounting the Elevator

1. Secure the elevator base (A) to the mounting base (102) using screws (104), lockwashers (103), and nuts (105). (Fig 3)
2. Bolt the mounting base (102) to the floor for stability.
3. Verify the elevator is level. Loosen on or two screws (104) on the elevator base and place shims under the base, if necessary.

4. Place the inductor plate (2, 18, or 22) on the mounting base (102).

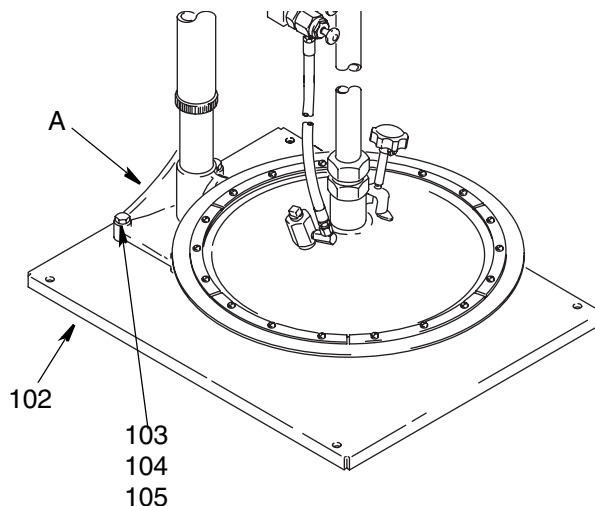

FIG. 3

5. Loosen the screws (68) of both support brackets (83). Slide the support (64) down far enough to allow installation of the pump in the inductor plate. Tighten the bracket screws lightly.

## Mounting the Pump

Models 226013, 226018, 244637

1. Mount the pump support bracket (86). (FIG. 4)

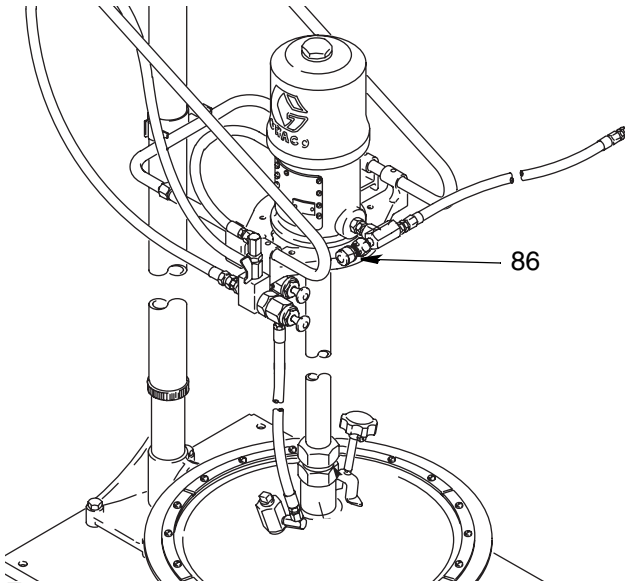

FIG. 4

2. Remove inductor plate nut (11 or 24), locking ring (8 or 23) and o-ring (9). (FIG. 5)
3. In order, slide inductor plate nut (11 or 24), locking ring (8 or 23) and o-ring (9) on pump riser tube. (FIG. 5)
4. Adjust the inductor plate on the pump so that the pump intake is 0.12 in. (3.2 mm) above the mounting base.

5. Tighten the lock nut (11 or 24) securely. Continue with Step 4 below.

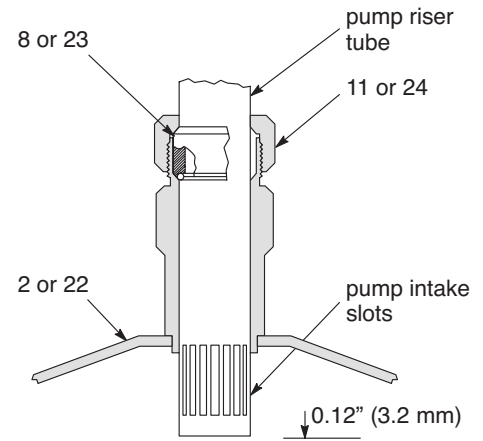

FIG. 5

**NOTE:** The full length of the pump intake slots must be just below the bottom of the inductor cone.

### Model 204490

Refer to FIG. 6 for Steps 1-3 below.

1. Lubricate the o-ring (20) in the inductor plate (18) with light, waterproof grease. (FIG. 6)
2. Mount the pump on the pump support (64) so the fluid outlet faces front.
3. Guide the pump intake valve as far as possible into the inductor plate, then tighten the set screws (19). Continue with Step 4 below.

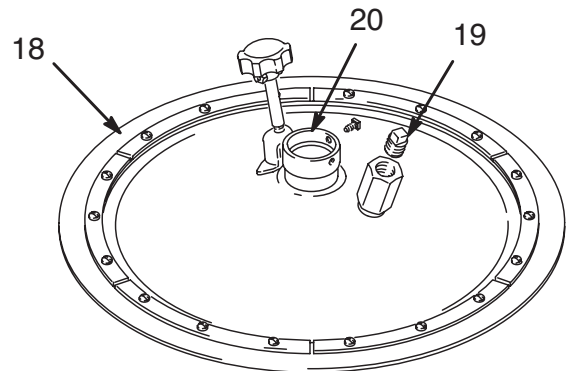

FIG. 6

**All Models**

Refer to FIG. 7 for the following Steps.

4. Loosen the pump support clamps again and raise the support (64) until it meets the pump base.
5. Secure the President or Fire-Ball pump to the pump support mounting plates from the underside with the screws (68).
6. Tighten screws (68) on lower pump bracket (83).
7. Slide the upper support bracket (83) up or down (the tubing of the pump support (64) will flex slightly) until the pump is in a true vertical position.
8. Tighten the screws (68) on the upper bracket.

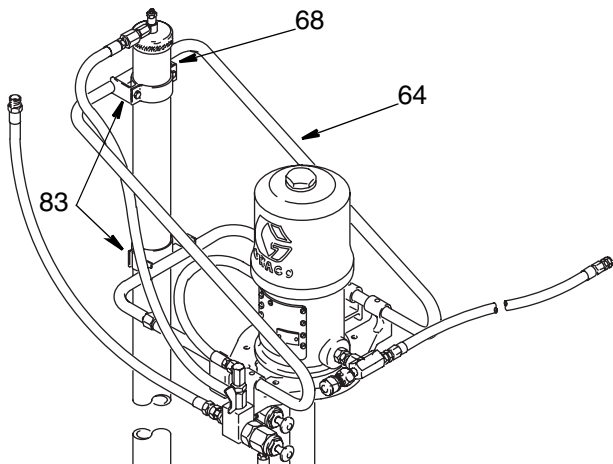
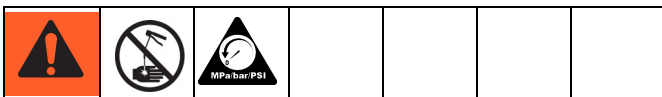

FIG. 7

**Installing the Hoses and Valves**



**NOTE:** Use thread sealant on all male threads except at the swivel unions.

1. Remove the plug from the top of the elevator cap and screw it into the air inlet (E) in the elevator base. (FIG. 8)
1. Screw the restrictor valve assembly (42) into the elevator cap.
2. Screw the 1/4 x 1/8 npt adapter (85) into the restrictor valve. (FIG. 8)
3. Install the 1/4 x 3/8 npt adapter (89). (FIG. 8)

4. Connect one end of the 36 in. (914 mm) hose into the adapter and the other hose end into the snap-over valve's (27) union. (FIG. 8)

<p>The bleed-type master air valve is required in your system to relieve air trapped between this valve and the pump after the air is shut off. Trapped air can cause the pump to cycle unexpectedly and cause serious injury, including splashing in the eyes or on the skin. Position the valve close to the pump.</p>					

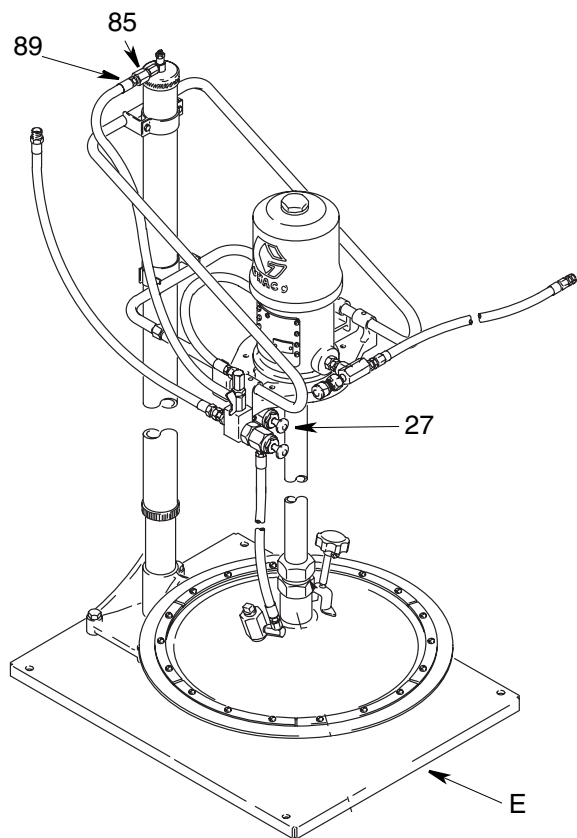

FIG. 8

5. Route the hose inside the arms of the pump support (64). (FIG. 7)
6. Screw the hex nipple (115 or 99) from the outlet hose kit (91 or 97) to the pump outlet. (See Parts Drawing on Page 16.)
7. Connect the kit's swivel union (96) to the adapter with the opening in the valve (94) facing down. (See Parts Drawing on Page 18.)



8. Install a bleed-type master air valve on the pump's air supply line.
9. Install a fluid shutoff valve on the fluid supply line to shut off fluid to the pump.
10. Finish assembling the hoses and fittings as shown on Parts Drawing Page 16.

# Operation

## NOTICE

Always close the ball valve (65) as soon as the inductor plate reaches the bottom of the drum, indicating the drum is empty. Allowing the pump to run without fluid will cause damage to the pump.

## Installing a Drum



Refer to FIG. 9 for the following instructions.

1. Relieve the pressure, see Pressure Relief Procedure, page 5.
2. Close the ball valve (65). The handle will be at a 90° angle to the valve body.
3. Open the bleed-type master air valve (F).
4. Open the inductor plate vent by turning the knob (10) counter clockwise.
5. Pull open the snap-over valve (27) to raise the elevator.

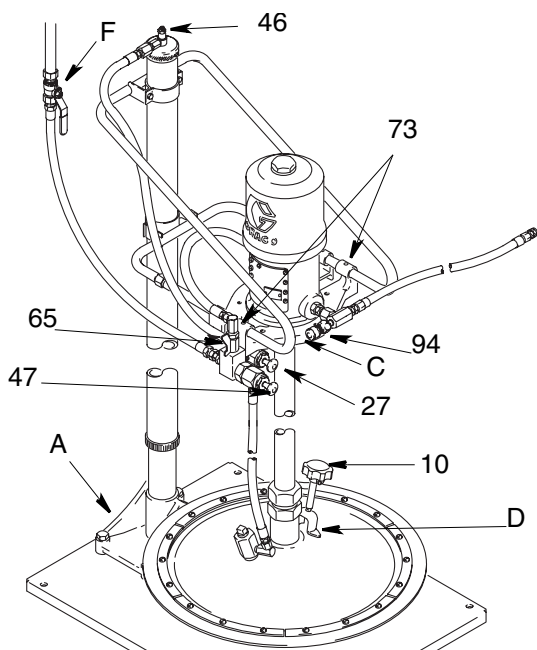

FIG. 9

**NOTE:** To adjust the elevator speed, turn the restrictor valve screw (46) clockwise to decrease the speed or counter clockwise to increase the speed.

6. Center an opened 400 lb (181.4 kg) drum under the inductor plate so the drum bottom touches the elevator base (A).
7. Make the top of the fluid concave by scooping fluid from the center to the sides of the container.
8. Loosen the setscrews (73), holding pump mounting plates to the mounting bracket (C). Align the pump and inductor plate with the drum.

**NOTE:** Keep your fingers and hands away from the sides of the drum or inductor plate to avoid pinching them when raising and lowering the pump.

9. Push in the snap-over valve (27) to lower the pump while guiding the inductor plate into the drum.
10. Press down the pump and rock it back and forth to seat the inductor plate. This helps eliminate air trapped beneath the plate. Continue this action until fluid appears at the vent opening (D).
11. Be sure that the pump is aligned vertically and tighten the set screws (73).
12. Close the inductor plate vent by turning the knob (10) clockwise.

**13. For Models 226013, 226018, and 244637 only:**

- a. Open the bleeder valve (94) at the pump outlet by turning the thumbscrew counter clockwise.
- b. Open the ball valve (65) until all air trapped in the pump and under the plate are pumped through the valve.
- c. Close the ball valve and the bleeder valve.
- d. Regulate the pump speed with the ball valve handle.

14. **All Models:** Always use the lowest possible pump pressure necessary for good delivery. Higher pressures cause premature pump wear and usually do not produce better results.

## Removing a Drum

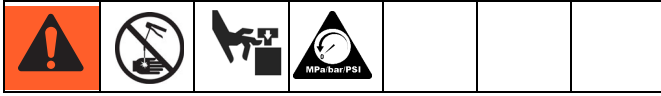

1. Relieve pressure, see Pressure Relief Procedure, page 5.
2. Press in and hold the air-assist valve (47) until the inductor plate rises above the drum. Release the valve. (FIG. 9)
3. Open the snap-over valve (27) and raise the elevator to full height. (FIG. 9)

**NOTE:** If you lose air pressure when reaching the drum chime, continue holding the air-assist valve and slowly pull out the snap-over valve until the chime is passed. Then, immediately close the snap-over valve to prevent raising the drum off the floor.

# Maintenance

Refer to FIG. 10 for reference numbers.

**NOTE:** To avoid contaminating the fluid in the supply container, keep the pump intake and the inductor plate clean during the servicing operations. Place the parts on clean paper or rags.

## Removing the Pump



1. Relieve Pressure, see Pressure Relief Procedure, page 5.
2. Remove the drum. Disconnect the air-assist hose (41).

*For Model 204490:* Loosen the inductor plate set screws (19).

*For Models 226013, 226018, and 244637:* Unscrew the locking nut (11 or 24), taking note of the number of turns needed.

3. Push the snap-over valve (27) to lower the pump.
4. Relieve pressure in the pump and disconnect the hoses.
5. Disconnect the pump from the mounting bracket and remove it.

## Reinstalling the Pump

1. Connect the pump to the mounting bracket.
2. Attached hoses to pump.
3. Pull the snap-over valve (27) to raise the pump.
4. Attach drum. See Installing a Drum, page 10.

**NOTE:** When attaching the pump to the inductor plate, turn the locking nut (11 or 24) the same number of turns noted in Removing the Pump, Step 2, or until you feel it settle in.

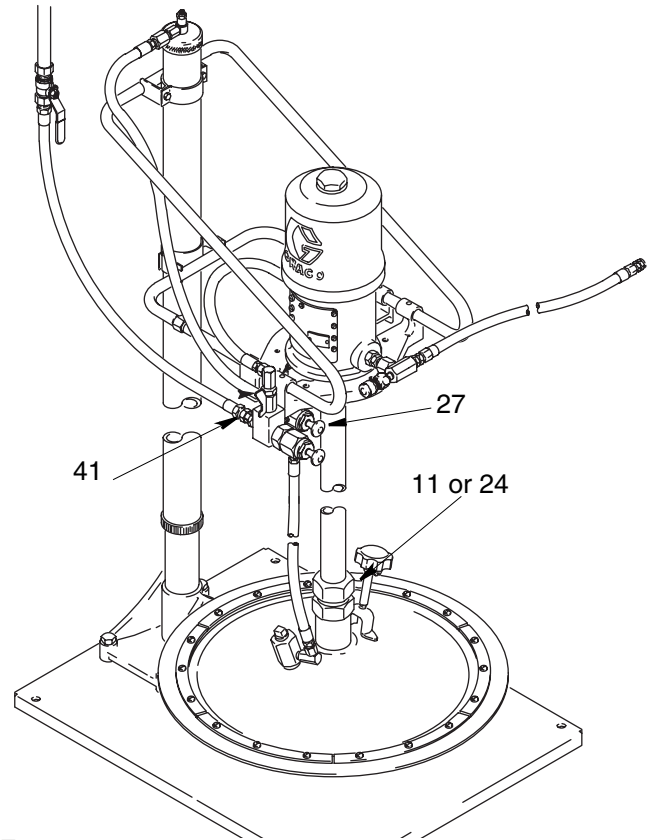

FIG. 10

# Troubleshooting



Problem	Cause	Solution
Low flow or air sucked into pump or under inductor plate.	<ol style="list-style-type: none"> <li>1. Open inductor plate vent</li> <li>2. Loose inductor plate sleeve locking nut</li> <li>3. Worn inductor seals</li> </ol>	<ol style="list-style-type: none"> <li>1. Close the inductor plate.</li> <li>2. Tighten the locking nuts.</li> <li>3. Replace seals; See Parts Drawing Page 16.</li> </ol>
Failure of snap-valve or air-assist valve	Worn o-rings or seals	Remove valve, place in vise, disassemble and replace parts as needed.

# Parts

## Model 204490

### Elevator and Inductor Plate Assembly

Includes items 17, 25, 90, and 101

#### Ref Parts

Ref No.	Part No.	Description	Qty.
17	204405	INDUCTOR PLATE ASSEMBLY See parts on page 14	1
25	204461	WISHBONE SUPPORT ASSEMBLY See parts on page 16	1
90	204385	PNEUMATIC ELEVATOR See manual 306287 for parts	1
101	205339	ELEVATOR BASE See parts below	1

## Model 226013

### Pump, Elevator, and Inductor Plate Assembly

Includes items 1, 25, 89, 90, 91 and 101

Ref No.	Part No.	Description	Qty.
1	204353	INDUCTOR PLATE ASSEMBLY See parts on page 14	1
25	204461	WISHBONE SUPPORT ASSEMBLY See parts on page 16	1
89	239888	50:1 RATIO FIRE-BALL PUMP See manual 308883 for parts	1
90	204385	PNEUMATIC ELEVATOR See manual 306287 for parts	1
91	204467	HOSE KIT See parts on page 18	1
101	205339	ELEVATOR BASE See parts below	1

## Model 226018

### Pump, Elevator, and Inductor Plate Assembly

Includes items 21, 25, 90, 97, 101, and 106

Ref No.	Part No.	Description	Qty.
21	205699	INDUCTOR PLATE ASSEMBLY See part on page 14	1
25	204461	WISHBONE SUPPORT ASSEMBLY See parts on page 16	1
90	204385	PNEUMATIC ELEVATOR See manual 306287 for parts	1
97	205102	HOSE KIT See parts on page 18	1
101	205339	ELEVATOR BASE See parts below	1
106	205395	50:1 RATIO PRESIDENT PUMP See manual 306674 for parts	1

## Model 244637

### Pump, Elevator, and Inductor Plate Assembly

Includes items 21, 25, 90, 97, 101, and 107

Ref No.	Part No.	Description	Qty.
21	205669	INDUCTOR PLATE ASSEMBLY See Parts on Page 14	1
25	204461	WISHBONE SUPPORT ASSEMBLY See parts on page 16	1
90	204385	PNEUMATIC ELEVATOR See manual 306287 for parts	1
97	205102	HOSE KIT See parts on page 18	1
101	205339	ELEVATOR BASE See parts below	1
107	239730	75:1 RATIO PRESIDENT PUMP See manual 308777 for parts	1

#### Ref No. 101: Part No. 205339

#### Elevator Base Assembly

Includes items 102 - 105

Ref No.	Part No.	Description	Qty.
102	205340	BASE, elevator	1
103	100018	LOCKWASHERS, spring, 1/2"	4
104	100096	SCREW, hex hd cap, 1/2-13 x 2"	4
105	100321	NUT, 1/2-13	4

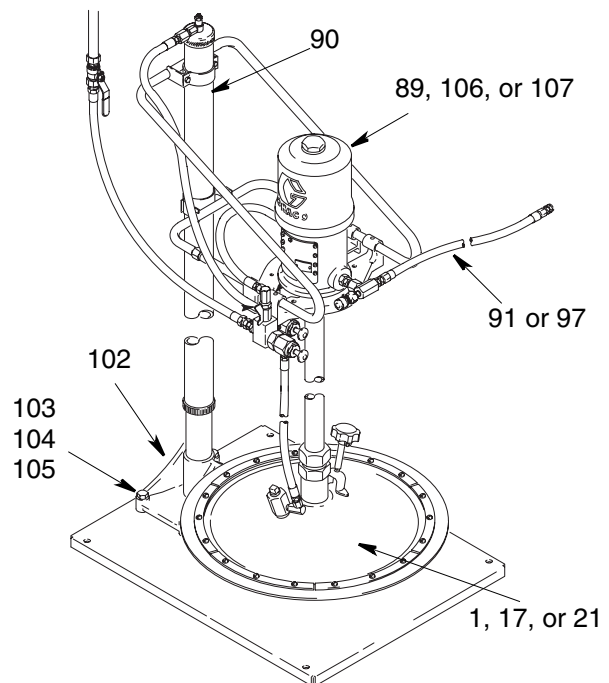

**Ref No. 1: Part No. 204353**

**Inductor Plate Assembly: 400 lb Drum size**

Fits 50:1 Fire-Ball In-Line Pump; Includes items 2-16

Ref No.	Part No.	Description	Qty.
2	204502	PLATE, inductor, bare	1
3	100015	NUT, hex, mscr, 1/4-20 UNC-2a	1
4	100021	CAPSCREW, hex hd, 1/4-20 UNC-2a x 1"	1
5	104663	PLUG, pipe, 3/4 npt (f)	1
6	100799	SCREW, mach, rd hd, 1/4-20 x 1/2"	18
7	100859	SCREW, headless, full dog point, No. 10-24 x 1/4"	1
8	101644	SLEEVE, coupling	1
9	158776	O-RING	1
10	160865	KNOB, vent	1
11	161107	NUT, locking	1
12	161162	SEAL, rubber	1
13	161287	WIPER, inductor plate	1
14	161288	SEGMENT, full barrel	6
15	164432	CAP, vent	1
16	164497	ROD, vent release	1

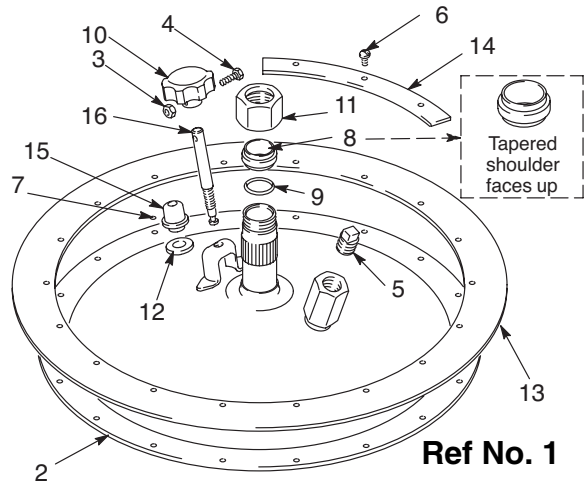

**Ref No. 17: Part No. 204405**

**Inductor Plate Assembly: 400 lb Drum size**

Fits Monarch and President In-Line Pumps

Includes items 3 - 7, 10, 12 - 16, 18 - 20

Ref No.	Part No.	Description	Qty.
3	100015	NUT, hex, mscr, 1/4-20 UNC-2a	1
4	100021	CAPSCREW, hex hd, 1/4-20 UNC-2a x 1"	1
5	104663	PLUG, pipe, 3/4 npt (f)	1
6	100799	SCREW, mach, rd hd, 1/4-20 x 1/2"	18
7	100859	SCREW, headless, full dog point, No. 10-24 x 1/4"	1
10	160865	KNOB, vent	1
12	161162	SEAL, rubber	1
13	161287	WIPER, inductor plate	1
14	161288	SEGMENT, full barrel	6
15	164432	CAP, vent	1
16	164497	ROD, vent release	1
18	204507	PLATE, inductor, bare	1
19	100556	SETSCREW, sq hd cup point, 5/16-18 x 3/8"	2
20	160721	O-RING, nitrile rubber	1

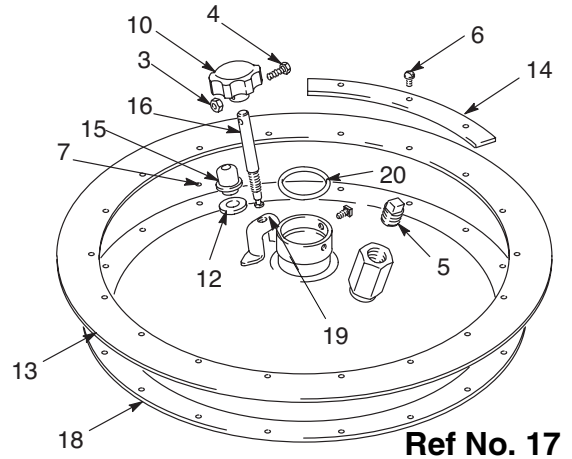

**Ref No. 21: Part No. 205699**

**Inductor Plate Assembly: 400 lb Drum size**

Fits 50:1 President In-Line Pumps

Includes items 3 - 7, 10, 12 - 16, and 22 - 24

Ref No.	Part No.	Description	Qty.
3	100015	NUT, hex, mscr, 1/4-20 UNC-2a	1
4	100021	CAPSCREW, hex hd, 1/4-20 UNC-2a x 1"	1
5	104663	PLUG, pipe, 3/4 npt (f)	1
6	100799	SCREW, mach, rd hd, 1/4-20 x 1/2"	18
7	100859	SCREW, headless, full dog point, No. 10-24 x 1/4"	1
10	160865	KNOB, vent	1
12	161162	SEAL, rubber	1
13	161287	WIPER, inductor plate	1
14	161288	SEGMENT, full barrel	6
15	164432	CAP, vent	1
16	164497	ROD, vent release	1
22	205698	PLATE, inductor, bare	1
23	196219	RING, locking	1
24	164962	NUT, collet	1

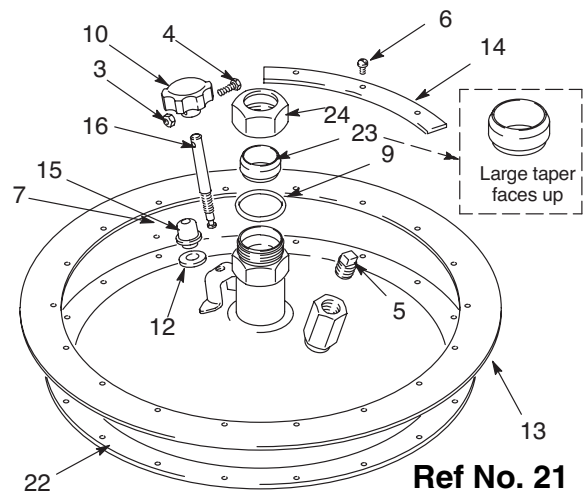

**Ref. No. 42**  
**Restrictor Valve Assembly**  
 Includes items 43 to 46

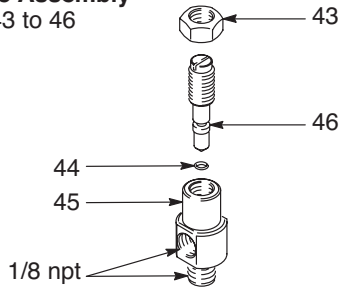

0729

**Ref. No. 27**  
**Snap-Over Valve Assembly**  
 Includes items 28 to 40

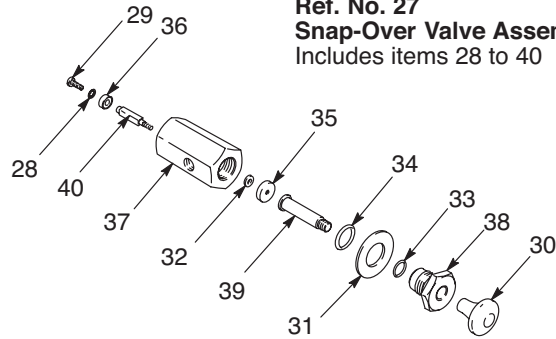

0730

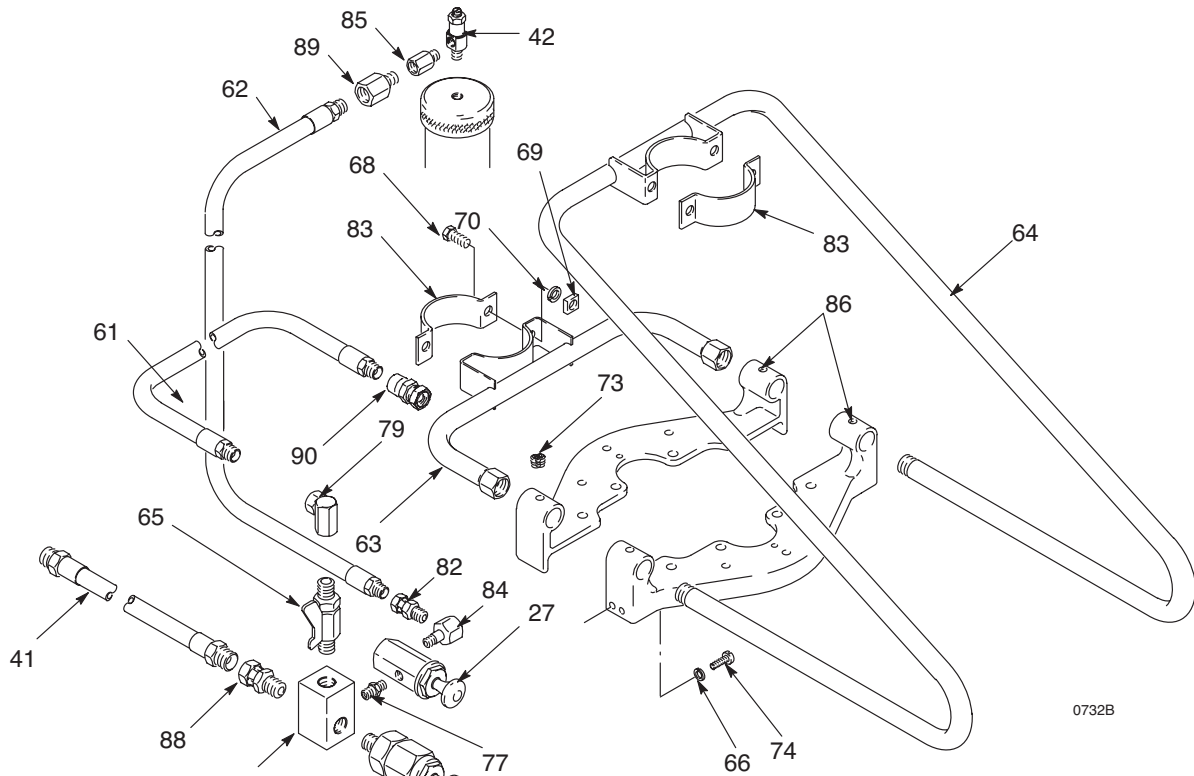

0732B

**Ref. No. 47**  
**Air Assist Valve Assembly**  
 Includes items 48 to 60

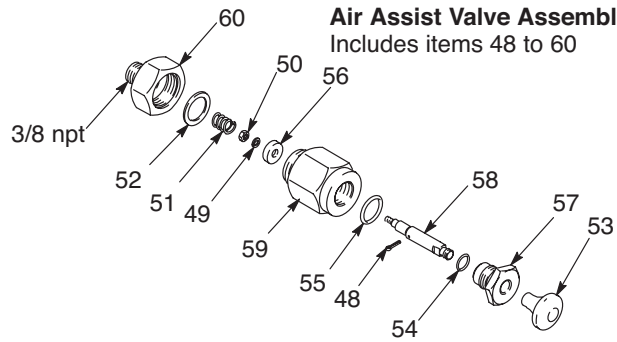

0731



**Ref No. 25: Part No. 204461  
Wishbone Support Assembly**

Ref No.	Part No.	Description	Qty.	Ref No.	Part No.	Description	Qty.
27	202295	SNAP-OVER VALVE ASSEMBLY Includes items 28 - 40		61	204560	HOSE, air, cpld 3/8 npt (m) 3/8" (9.6mm) ID, 18" (457 mm) long	1
28	100272	LOCKWASHER, int. shkprf, No. 6	1	62	204561	HOSE, air, cpld 3/8 npt (m) 3/8" (9.6mm) ID, 36" (914 mm) long	2
29	104560	SCREW, oval hd, 6-32 3/8"	1	63	205610	SUPPORT, pump, lower	1
30	154519	KNOB	1	64	205611	SUPPORT, pump, upper	1
31	154526	WASHER	1	65	208393	BALL VALVE	1
32	154570	WASHER	1	66	100016	LOCKWASHER, spring, 1/4"	4
33	154594	O-RING, buna-N	1	68	100057	CAPSCREW, hex hd, 5/16-18 x 3/4"	11
34	155500	O-RING, nitrile rubber	1	69	100181	NUT, square, 6/16-18	4
35	155811	SEAL, valve, nitrile rubber	1	70	100214	LOCKWASHERS, 5/16"	4
36	155921	SEAL, valve, nitrile rubber	1	71	100333	CAPSCREW, hex hd, 1/4-20 x 1/2"	4
37	157160	HOUSING, valve	1	72	100469	CAPSCREW, hex hd, 3/8-16 x 3/4"	4
38	157161	GUIDE, valve	1	73	100421	SETSCREW, socket hd, cup point, 5/16" x 3/8"	4
39	161129	STEM, valve, large	1	74	100377	SCREW, hex socket hd, 1/4-20 x 5/8"	2
40	161132	STEM, valve, small	1	76	150718	CLAMP, drum	4
41	205418	HOSE, air, cpld 1/2 npt(m) 1/2" (13mm) ID, 6' (1.8 m) long	1	77	151243	ADAPTER, 1/8 npt(m)	1
42	203743	RESTRICTOR VALVE ASSEMBLY Includes items 43 - 46	1	78	155541	UNION, 90° street, 1/4 npt (m x f) swivel	1
43	101448	NUT, jam, 3/8-24	1	79	155677	UNION, 90° adapter, 3/8 npt (f)	1
44	157628	O-RING, nitrile rubber	1	80	155699	ELBOW, street, 3/8 npt (m x f)	1
45	160162	HOUSING, valve	1	81	156580	ADAPTER, 3/8 npt(f) x 1/8 npt(m)	1
46	160163	NEEDLE VALVE	1	82	156823	UNION, 1/4 npt(m x f) swivel	1
47	203842	AIR ASSIST VALVE ASSEMBLY Includes items 48 - 60	1	83	158271	BRACKET, elevator riser tube, 1/8 npt	2
48	100063	PIN, cotter, 1/6" dia x 1/2"	1	84	158962	ELBOW, 90° street, 1/4 npt(f) x 1/8 npt (m)	1
49	100068	LOCKWASHERS, spring, No. 6	1	85	159840	ADAPTER, pump mounting, 1/4 npt(f) x 1/8 npt(m)	1
50	100072	NUT, hex, No. 6-32	1	86	189211	BRACKET, pump mounting	2
51	150902	SPRING, compression	1	87	161466	MANIFOLD, air	1
52	153348	GASKET, copper	1	88	162505	UNION, swivel, 3/8 npt(m) x 1/2 npsm(f) swivel	1
53	154519	KNOB	1	89	150287	ADAPTER, 1/4 npt(m) x 3/8 npt(f)	1
54	154594	O-RING, buna-N	1	90	158256	UNION, swivel, 1/2 npt(m) x 3/8 npsm(f) swivel (used with model 226018 President pump only)	1
55	155500	O-RING, nitrile rubber	1				
56	155811	SEAL, valve, nitrile rubber	1				
57	157161	GUIDE, valve	1				
58	160401	STEM, valve	1				
59	160402	HOUSING, valve	1				
60	160404	STUD, valve	1				

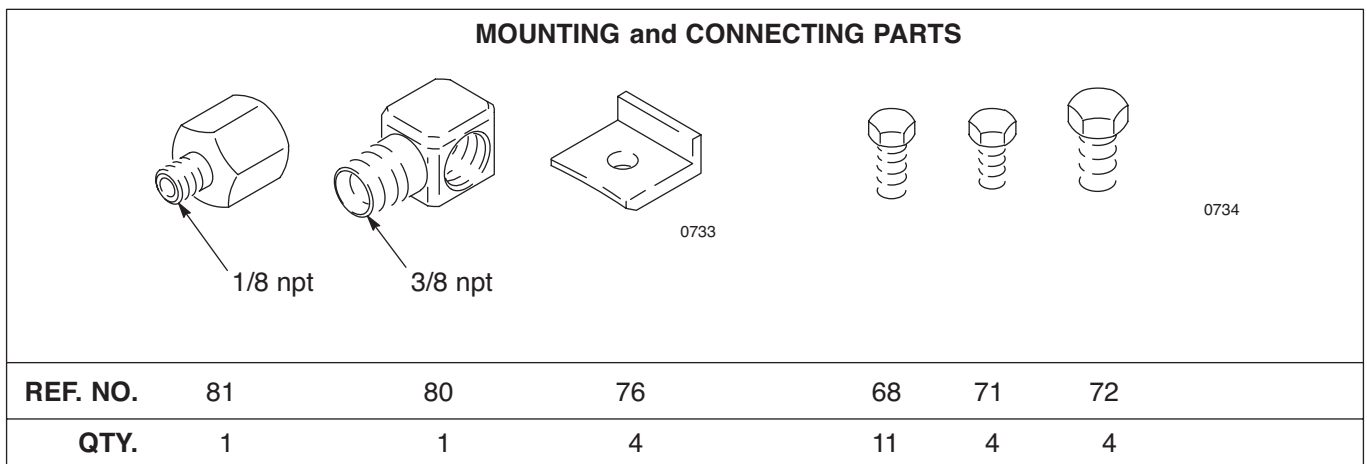

**Ref No. 91: Part No. 204467**  
**Fire-Ball Delivery Hose Kit**

Includes items 92 - 94, 96, and 115

Ref No.	Part No.	Description	Qty.
92	100206	BUSHING, 1/2 npt(m) x 1/4 npt(f)	1
93	109150	HOSE, fluid, cpld 1/4 npt(m), 1/4" (6.4mm) ID, 6' (1.83 m) long	1
94	205528	VALVE, bleeder	1
96	160878	UNION, 90°, 1/4 npt(f) swivel	1
115	156971	NIPPLE, 1/4 x 1/4 npt(m)	1

**Ref No. 97: Part No. 205102**  
**President Delivery Hose Kit**

Includes items 94, 96, 98, 99, and 110

Ref No.	Part No.	Description	Qty.
94	205528	VALVE, bleeder	1
96	160878	UNION, 90°, 1/4 npt(f) swivel	1
98	109163	HOSE, cpld 3/8 npt(m), 3/8" (9.6mm) ID, 6' (1.83 m) long	1
99	156849	NIPPLE, hex, 3/8 npt(m)	1
110	100081	BUSHING, pipe, 1/2 npt(m) x 3/8 npt(f)	1

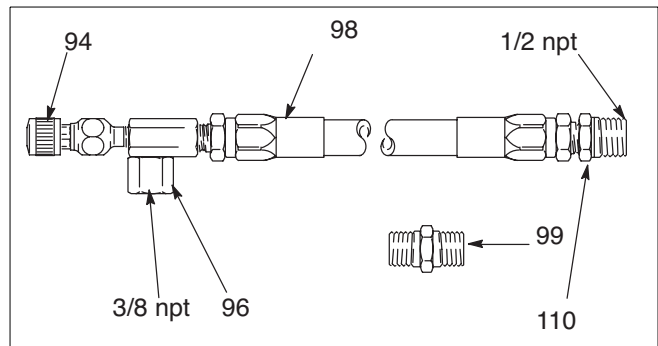
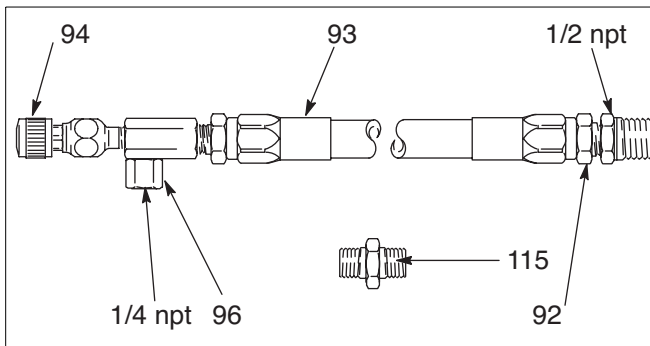

**Dimensions**

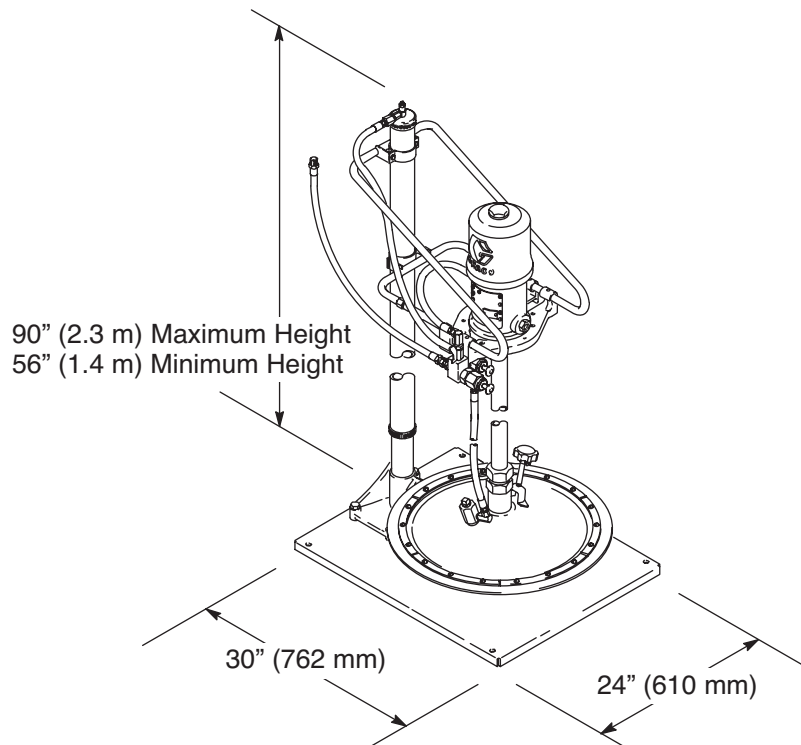

# Technical Data

See the pump instruction manual for Technical Data including Wetted Parts, Port Sizes, and so on.

<b>Topper Units</b>		
	<b>US</b>	<b>Metric</b>
<b>Maximum fluid working pressure</b>		
50:1 Ratio Fire-Ball Pump	5000 psi	34.5 MPa, 345 bar
50:1 Ratio President Pump	4000 psi	28 MPa, 280 bar
75:1 Ratio President Pump	4000 psi	28 MPa, 280 bar
<b>Maximum air pressure</b>		
50:1 Ratio Fire-Ball Pump	100 psi	0.7 MPa, 7bar
50:1 Ratio President Pump	80 psi	0.6 MPa, 6 bar
75:1 Ratio President Pump	80 psi	0.6 MPa, 6 bar
<b>Weight</b>		
Model 226013 50:1 Ratio Fire-Ball Pump	122 lb	55 kg
Model 226018 50:1 Ratio President Pump	136 lb	61 kg
Model 244637 75:1 Ratio President Pump	136 lb	61 kg
Model 204490 Elevator and Inductor	90 lb	41 kg
<b>Maximum sound pressure tested at 100 psi (0.7 MPa, 7 bar) at 40 cycles per minute</b>		
Model 226013 50:1 Ratio Fire-Ball Pump	77.8 dB(A)	
<b>Maximum sound pressure tested at 100 psi (0.7 MPa, 7 bar) at 15 cycles per minute</b>		
Model 226018 50:1 Ratio President Pump	80.9 dB(A)	
Model 244637 75:1 Ratio President Pump	80.9 dB(A)	
<b>Maximum sound power lever tested in accordance with ISO 9614-2</b>		
Model 226013 50:1 Ratio Fire-Ball Pump	85.6 dB(A)	
<b>Maximum sound power lever tested in accordance with ISO 9614-2</b>		
Model 226018 50:1 Ratio President Pump	94.6 dB(A)	
Model 244637 75:1 Ratio President Pump	94.6 dB(A)	

# Graco Standard Warranty

Graco warrants all equipment referenced in this document which is manufactured by Graco and bearing its name to be free from defects in material and workmanship on the date of sale to the original purchaser for use. With the exception of any special, extended, or limited warranty published by Graco, Graco will, for a period of twelve months from the date of sale, repair or replace any part of the equipment determined by Graco to be defective. This warranty applies only when the equipment is installed, operated and maintained in accordance with Graco's written recommendations.

This warranty does not cover, and Graco shall not be liable for general wear and tear, or any malfunction, damage or wear caused by faulty installation, misapplication, abrasion, corrosion, inadequate or improper maintenance, negligence, accident, tampering, or substitution of non-Graco component parts. Nor shall Graco be liable for malfunction, damage or wear caused by the incompatibility of Graco equipment with structures, accessories, equipment or materials not supplied by Graco, or the improper design, manufacture, installation, operation or maintenance of structures, accessories, equipment or materials not supplied by Graco.

This warranty is conditioned upon the prepaid return of the equipment claimed to be defective to an authorized Graco distributor for verification of the claimed defect. If the claimed defect is verified, Graco will repair or replace free of charge any defective parts. The equipment will be returned to the original purchaser transportation prepaid. If inspection of the equipment does not disclose any defect in material or workmanship, repairs will be made at a reasonable charge, which charges may include the costs of parts, labor, and transportation.

**THIS WARRANTY IS EXCLUSIVE, AND IS IN LIEU OF ANY OTHER WARRANTIES, EXPRESS OR IMPLIED, INCLUDING BUT NOT LIMITED TO WARRANTY OF MERCHANTABILITY OR WARRANTY OF FITNESS FOR A PARTICULAR PURPOSE.**

Graco's sole obligation and buyer's sole remedy for any breach of warranty shall be as set forth above. The buyer agrees that no other remedy (including, but not limited to, incidental or consequential damages for lost profits, lost sales, injury to person or property, or any other incidental or consequential loss) shall be available. Any action for breach of warranty must be brought within two (2) years of the date of sale.

**GRACO MAKES NO WARRANTY, AND DISCLAIMS ALL IMPLIED WARRANTIES OF MERCHANTABILITY AND FITNESS FOR A PARTICULAR PURPOSE, IN CONNECTION WITH ACCESSORIES, EQUIPMENT, MATERIALS OR COMPONENTS SOLD BUT NOT MANUFACTURED BY GRACO.** These items sold, but not manufactured by Graco (such as electric motors, switches, hose, etc.), are subject to the warranty, if any, of their manufacturer. Graco will provide purchaser with reasonable assistance in making any claim for breach of these warranties.

In no event will Graco be liable for indirect, incidental, special or consequential damages resulting from Graco supplying equipment hereunder, or the furnishing, performance, or use of any products or other goods sold hereto, whether due to a breach of contract, breach of warranty, the negligence of Graco, or otherwise.

## **FOR GRACO CANADA CUSTOMERS**

The Parties acknowledge that they have required that the present document, as well as all documents, notices and legal proceedings entered into, given or instituted pursuant hereto or relating directly or indirectly hereto, be drawn up in English. Les parties reconnaissent avoir convenu que la rédaction du présente document sera en Anglais, ainsi que tous documents, avis et procédures judiciaires exécutés, donnés ou intentés, à la suite de ou en rapport, directement ou indirectement, avec les procédures concernées.

# Graco Information

For the latest information about Graco products, visit [www.graco.com](http://www.graco.com).

**TO PLACE AN ORDER**, contact your Graco distributor or call to identify the nearest distributor.

**Phone:** 612-623-6928 or **Toll Free:** 1-800-533-9655, **Fax:** 612-378-3590

*All written and visual data contained in this document reflects the latest product information available at the time of publication.  
Graco reserves the right to make changes at any time without notice.*

*For patent information, see [www.graco.com/patents](http://www.graco.com/patents).*

Original instructions. This manual contains English. MM 306556

**Graco Headquarters:** Minneapolis  
**International Offices:** Belgium, China, Japan, Korea

**GRACO INC. AND SUBSIDIARIES • P.O. BOX 1441 • MINNEAPOLIS MN 55440-1441 • USA**

**Copyright 1956, Graco Inc. All Graco manufacturing locations are registered to ISO 9001.**

[www.graco.com](http://www.graco.com)

Revised November 2012